

DOORLEC  
CORPORATION

# ELECTRIC OPERATORS WITH DC2000 DEDICATED LOGIC CONTROLLER

- CONTROLS
- ACCESSORIES
- AUXILIARY EQUIPMENT

Retail Price List  
Fall 2024



## CONTROL & WIRING OPTIONS AT NO EXTRA CHARGE USING DC2000 DEDICATED LOGIC CONTROLLER

The following control wiring options are available as standard equipment in conjunction with all of our commercial/industrial door/gate/barrier electric operators listed on this price list at **NO EXTRA CHARGE**

- Wiring for push button station OPEN/CLOSE/STOP with **1.5 second delay** on open and close buttons.
- Wiring for reversing activators with **1.5 second delay**.
- Wiring for open or close activators with **1.5 second delay**.
- Wiring for radio control receiver with **1.5 second delay**.
- Wiring for automatic closing (timer) adjustable 10 to 180 seconds.
- Wiring for RED & GREEN warning lights adjustable 10 to 180 seconds.
- Slide switch for **MANUAL** or **AUTOMATIC MODE**.
- 115 V AC control circuit available for field connections of additional controls such as, loop detectors, photo electric control, card reader, motion detector , etc.,
- Long range activation capability up to 1200 ft. (365 meter) without the need of larger VA transformer.

NOTE: Slide switch on **MANUAL-MODE** automatic closing (Timer inactive, all other functions "ON".  
Slide switch on **AUTO-MODE** all functions "ON" but radio control and OPEN/CLOSE activators will only open door/gate/barrier and reset timer when energized.  
Close Button will override closing timer.

FOR FURTHERMORE DETAIL INFORMATION SEE BROCHURE E116

ALL MODELS AND ACCESSORIES  APPROVED

**THESE PRICE LISTS NO. E110B DATED AUGUST 2019  
SUPERSEDES ALL OTHER PRICE LISTS PREVIOUSLY PUBLISHED.**

### TWO YEARS LIMITED WARRANTY

Electric door/gate/barrier operators and auxiliary equipment sold by DOORLEC CORPORATION are under warranty for two years from date of invoice against defects in the material or workmanship under normal wear and service.

Controls and electrical accessories are under warranty for one year. Any part(s) or complete units which fail because of such defects within these periods, shall at the manufacturer's options be repaired or replaced at "NO CHARGE". The manufacturer will not be responsible for the transportation and or field labor or mileage charges. Replacement part(s) will be warranty for the remaining portion of warranty period. Freight for part(s) and complete operator(s) return for repairs or verification must be prepaid. This warranty becomes null and void if it is established that equipment has been damaged due to faulty or improper wiring, or misuse or negligence.

A continuing program is in effect at DOORLEC CORPORATION.

We reserve the right to incorporate product improvement at any time without notice  
(COPYRIGHT 2024 - ALL RIGHTS RESERVED)



# MODEL ETH-A

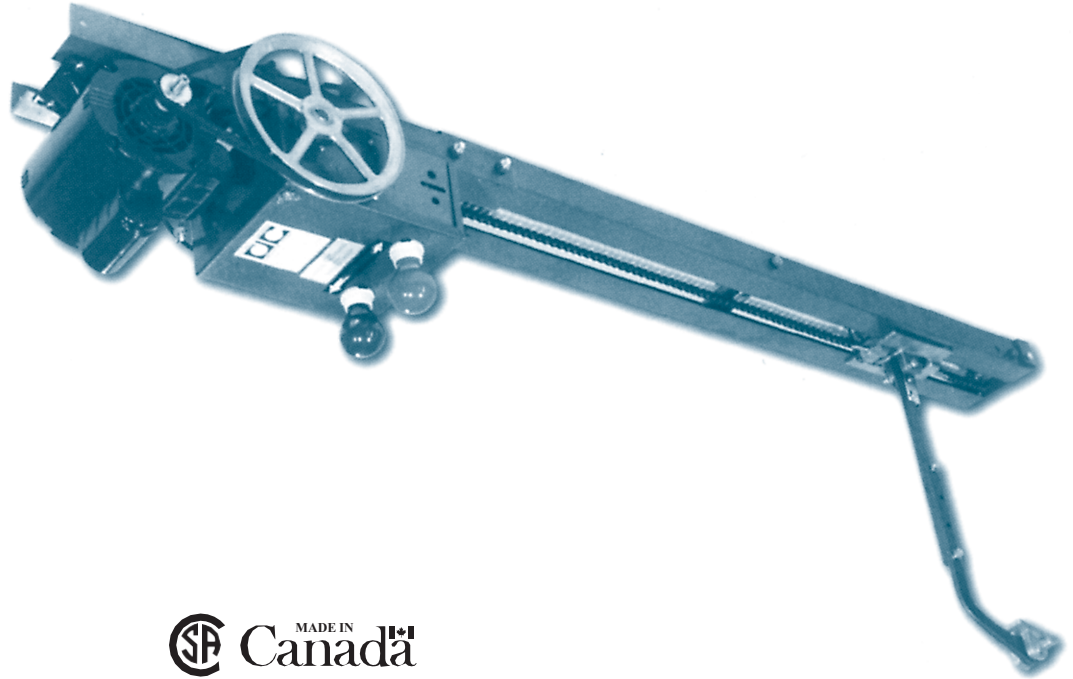

## TROLLEY TYPE APARTMENT BUILDING ELECTRIC DOOR OPERATOR WITH DC2000 DEDICATED LOGIC CONTROLLER



### HORSEPOWERS ELECTION GUIDE

Motor	Door of wood or aluminium	Fiberglass	Steel door 20 ga.	Maximum door ht.	Unbalanced door wt.
1/3 H.P. 249W	196 sq.ft. 18,2m <sup>2</sup>	225 sq.ft. 20,0m <sup>2</sup>	144 sq.ft. 13,4m <sup>2</sup>	16'0" 4,9m	700 lbs. 318 kg.

**NEW MODIFIED** AVAILABLE IN ALL VOLTAGES FOR HIGH-CYCLE OPERATION OF GARAGE WITH PARKING CAPACITY OF UP TO 75 CARS.

Standard equipment; for fully automatic operation.

Wiring for radio control system.

Reversing contactor.

High-speed ball bearings.

Heavy-duty roller chain #41.

Dual timer.

Temporized red & green warning lights.

Built-in pressure sensing mechanical reverse with 1.5 second delay.

Electrical reverse wiring with 1.5 second delay.

Wiring for Open or Close devices.

MODEL	H.P.	VOLTAGE-PHASE	CONTROL CIRCUIT	RETAIL PRICE
ETH-A	1/3	115-1	24V.A.C.	1800.00
ETH-A	1/2	115-1	24V.A.C.	1840.00
ETH-A	1/3	230-1	24V.A.C.	1800.00
ETH-A	1/2	230-1	24V.A.C.	1840.00
ETH-A	1/3	208-3	24V.A.C.	1870.00
ETH-A	1/2	208-3	24V.A.C.	1930.00
ETH-A	1/3	460-3	24V.A.C.	1870.00
ETH-A	1/2	460-3	24V.A.C.	1930.00
ETH-A	1/3	575-3	24V.A.C.	1870.00
ETH-A	1/2	575-3	24V.A.C.	1930.00

#### MODIFICATIONS :

DOORS OVER 8' HIGH (for each additional foot

add to net price) ..... 25.50

REVERSE MOUNT (used for limited backroom 3' plus

door height (see drawing 3018) (part no. 50165) ..... 300.00

PRICE FOR CONTROLS (key-switch, pull-cord, etc.) see pages 38 to 43.

For additional information see catalogues E105A and E113A.

PRICE



**DOORLEC  
CORPORATION**

MANUFACTURERS OF ELECTRIC OPERATORS FOR  
DOORS, GATES AND TRAFFIC CONTROL, BARRIERS

# MODEL ET-3

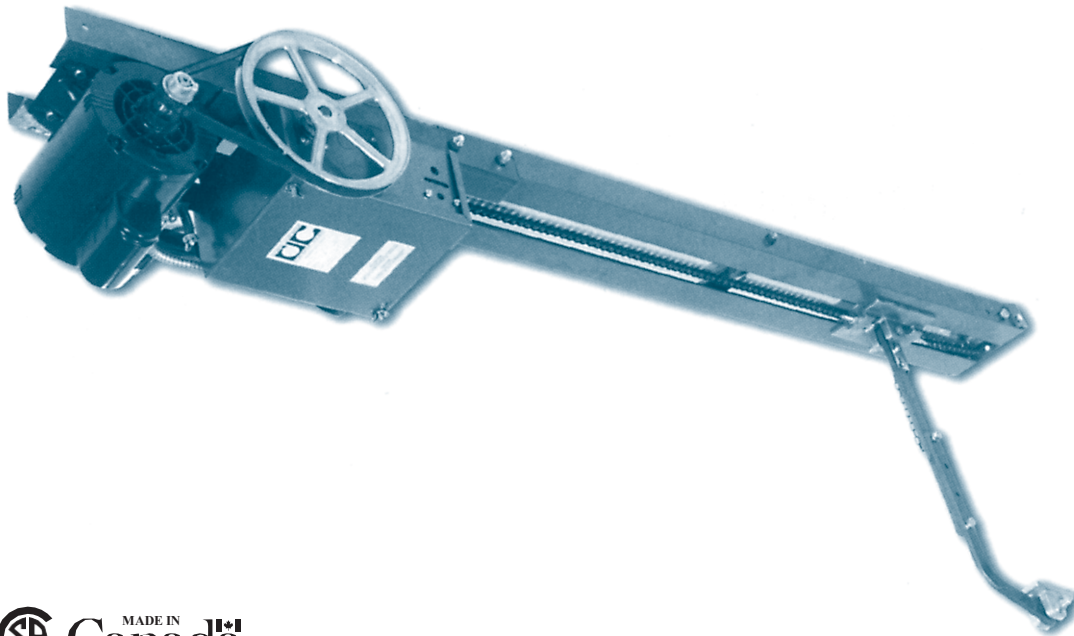

## TROLLEY TYPE COMMERCIAL AND INDUSTRIAL ELECTRIC DOOR OPERATOR WITH DC2000 DEDICATED LOGIC CONTROLLER

### HORSEPOWER SELECTION GUIDE

Motor	Door of wood or aluminium	Fiberglass	Steel door 20 ga.	Maximum door ht.	Unbalanced door wt.
1/3 H.P. 249W	224 sq.ft. 21m <sup>2</sup>	256 sq.ft. 24m <sup>2</sup>	144 sq.ft. 13,4m <sup>2</sup>	16'0" 4,9m	700 lbs. 318 kg.
1/2 H.P. 373W	256 sq.ft. 24m <sup>2</sup>	288 sq.ft. 27m <sup>2</sup>	256 sq.ft. 24m <sup>2</sup>	16'0" 4,9m	800 lbs. 363 kg.
3/4 H.P. 560W	288 sq.ft. 27m <sup>2</sup>	320 sq.ft. 30m <sup>2</sup>	288 sq.ft. 27m <sup>2</sup>	16'0" 4,9m	900 lbs. 408 kg.

MODEL	H.P.	VOLTAGE-PHASE	CONTROL CIRCUIT	RETAIL PRICE
ET-311	1/3	115-1	24V.A.C.	1580.00
ET-311	1/2	115-1	24V.A.C.	1620.00
ET-311	3/4	115-1	24V.A.C.	1680.00
ET-321	1/3	230-1	24V.A.C.	1580.00
ET-321	1/2	230-1	24V.A.C.	1620.00
ET-321	3/4	230-1	24V.A.C.	1680.00
ET-383	1/3	208-3	24V.A.C.	1680.00
ET-383	1/2	208-3	24V.A.C.	1710.00
ET-383	3/4	208-3	24V.A.C.	1740.00
ET-343	1/3	460-3	24V.A.C.	1680.00
ET-343	1/2	460-3	24V.A.C.	1710.00
ET-343	3/4	460-3	24V.A.C.	1740.00
ET-353	1/3	575-3	24V.A.C.	1680.00
ET-353	1/2	575-3	24V.A.C.	1710.00
ET-353	3/4	575-3	24V.A.C.	1740.00

PRICE

#### MODIFICATIONS:

OPERATORS WITH SINGLE AND THREE PHASE MOTORS have built-in pressure sensing electro-mechanical instant-reverse system at no extra charge.

REVERSE MOUNT (Used for limited backroom 3' plus door height) see drawing 3018 (part n° 50165).....300.00

Additional control circuit for 115V AC available at no extra charge.

DOORS OVER 14' HIGH (for additional foot)

add to net price .....25.50

PRICE FOR CONTROLS, AND ACCESSORIES see pages 38 to 43.

For additional information see catalogues E105A and E113A.



**DOORLEC  
CORPORATION**

MANUFACTURERS OF ELECTRIC OPERATORS FOR  
DOORS, GATES AND TRAFFIC CONTROL, BARRIERS

# MODEL ETB-3

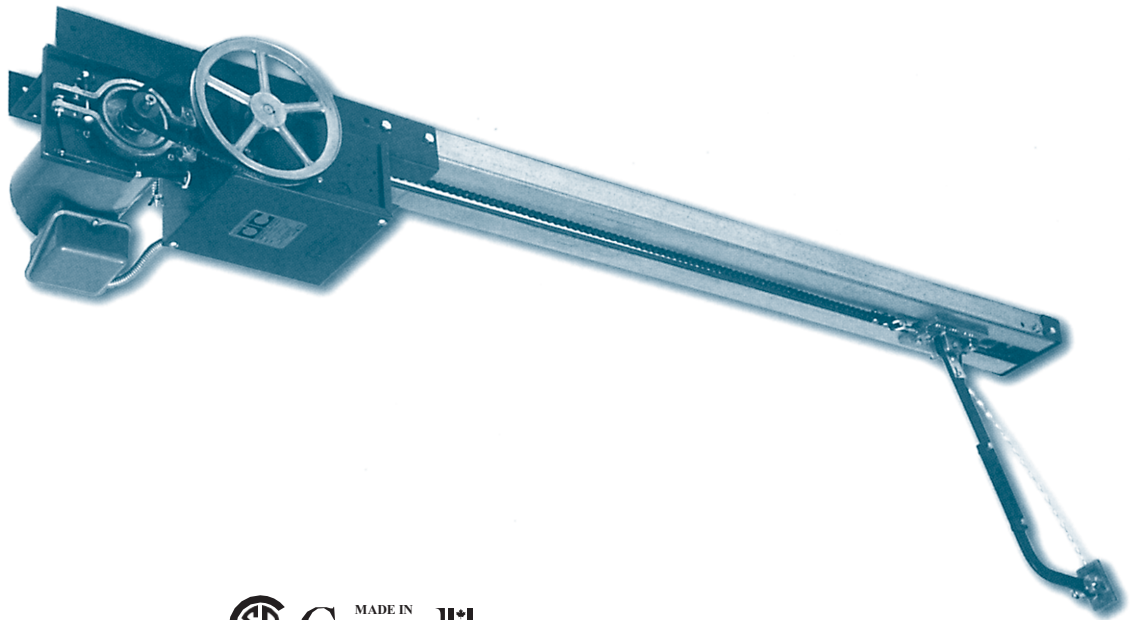

**TROLLEY TYPE  
COMMERCIAL  
AND INDUSTRIAL  
ELECTRIC DOOR  
OPERATOR  
WITH DC2000  
DEDICATED LOGIC  
CONTROLLER**

## HORSEPOWER SELECTION GUIDE

Motor	Door of wood or aluminium	Fiberglass	Steel door 20 ga.	Maximum door ht.	Unbalanced door wt.
1/3 H.P. 249W	224 sq.ft. 21m <sup>2</sup>	256 sq.ft. 24m <sup>2</sup>	144 sq.ft. 13,4m <sup>2</sup>	16'0" 4,9m	700 lbs. 318 kg.
1/2 H.P. 373W	256 sq.ft. 24m <sup>2</sup>	288 sq.ft. 27m <sup>2</sup>	256 sq.ft. 24m <sup>2</sup>	16'0" 4,9m	800 lbs. 363 kg.
3/4 H.P. 560W	288 sq.ft. 27m <sup>2</sup>	320 sq.ft. 30m <sup>2</sup>	288 sq.ft. 27m <sup>2</sup>	16'0" 4,9m	900 lbs. 408 kg.

MODEL	H.P.	VOLTAGE-PHASE	CONTROL CIRCUIT	RETAIL PRICE
ETB-311	1/3	115-1	24V.A.C.	1680.00
ETB-311	1/2	115-1	24V.A.C.	1710.00
ETB-311	3/4	115-1	24V.A.C.	1780.00
ETB-321	1/3	230-1	24V.A.C.	1680.00
ETB-321	1/2	230-1	24V.A.C.	1710.00
ETB-321	3/4	230-1	24V.A.C.	1780.00
ETB-383	1/3	208-3	24V.A.C.	1780.00
ETB-383	1/2	208-3	24V.A.C.	1810.00
ETB-383	3/4	208-3	24V.A.C.	1860.00
ETB-343	1/3	460-3	24V.A.C.	1780.00
ETB-343	1/2	460.3	24V.A.C.	1810.00
ETB-343	3/4	460-3	24V.A.C.	1860.00
ETB-353	1/3	575-3	24V.A.C.	1780.00
ETB-353	1/2	575-3	24V.A.C.	1810.00
ETB-353	3/4	575-3	24V.A.C.	1860.00

### MODIFICATIONS :

OPERATORS WITH SINGLE AND THREE PHASE MOTORS have built-in pressure sensing electro-mechanical instant-reverse system at no extra charge.

REVERSE MOUNT (Used for limited backroom 3' plus door height)

(see drawing 3018) (part n° 50165)..... 300.00

Additional control circuit for 115V AC available at no extra charge.

DOORS OVER 14' HIGH (for additional foot)

add to net price..... 25.50

PRICE FOR CONTROLS AND ACCESSORIES see pages 38 to 43.

For additional information see catalogues E105A and E113A.



**DOORLEC  
CORPORATION**

MANUFACTURERS OF ELECTRIC OPERATORS FOR  
DOORS, GATES AND TRAFFIC CONTROL, BARRIERS

# MODEL ETH

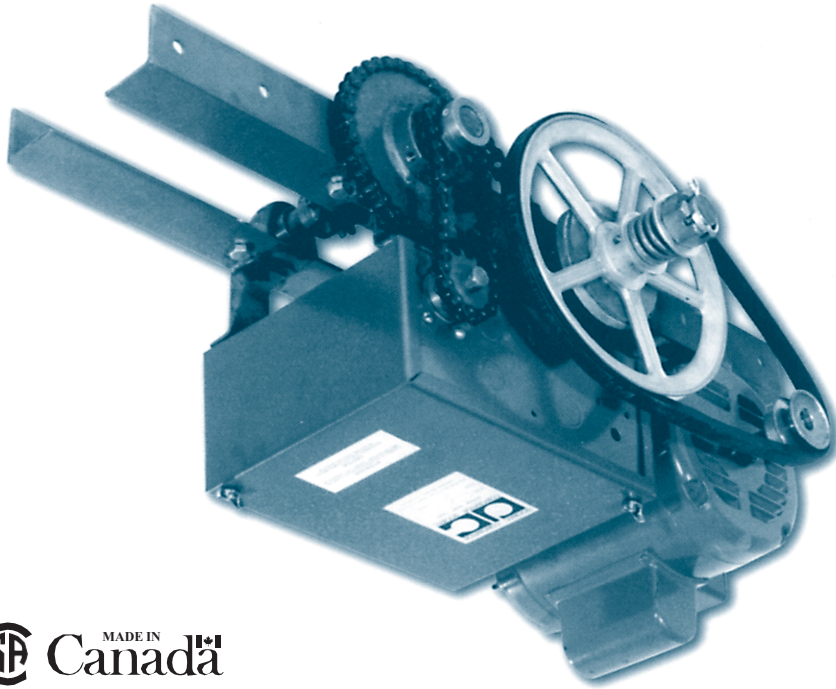

## HORSEPOWER SELECTION GUIDE

Motor	Door of wood or aluminium	Fiberglass	Steel door 20 ga.	Maximum door ht.	Unbalanced door wt.
1/3 H.P. 249W	288 sq.ft. 27m <sup>2</sup>	320 sq.ft. 30m <sup>2</sup>	224 sq.ft. 27m <sup>2</sup>	24'0" 7,3m	900 lbs. 408 kg.
1/2 H.P. 373W	320 sq.ft. 30m <sup>2</sup>	400 sq.ft. 37m <sup>2</sup>	256 sq.ft. 24m <sup>2</sup>	24'0" 7,3m	1200 lbs. 544 kg.
3/4 H.P. 560W	400 sq.ft. 37m <sup>2</sup>	576 sq.ft. 53m <sup>2</sup>	288 sq.ft. 27m <sup>2</sup>	24'0" 7,3m	1500 lbs. 680 kg.
1 H.P. 746W	576 sq.ft. 54m <sup>2</sup>	624 sq.ft. 58m <sup>2</sup>	320 sq.ft. 30m <sup>2</sup>	24'0" 7,3m	2000 lbs. 907 kg.

MODEL	H.P.	VOLTAGE-PHASE	CONTROL CIRCUIT	RETAIL PRICE
ETH-311	1/3	115-1	24V.A.C.	1700.00
ETH-311	1/2	115-1	24V.A.C.	1730.00
ETH-311	3/4	115-1	24V.A.C.	1800.00
ETH-321	1/3	230-1	24V.A.C.	1700.00
ETH-321	1/2	230-1	24V.A.C.	1730.00
ETH-321	3/4	230-1	24V.A.C.	1800.00
ETH-383	1/3	208-3	24V.A.C.	1780.00
ETH-383	1/2	208-3	24V.A.C.	1810.00
ETH-383	3/4	208-3	24V.A.C.	1840.00
ETH-383	1	208-3	24V.A.C.	1870.00
ETH-343	1/3	460-3	24V.A.C.	1780.00
ETH-343	1/2	460-3	24V.A.C.	1810.00
ETH-343	3/4	460-3	24V.A.C.	1840.00
ETH-343	1	460-3	24V.A.C.	1870.00
ETH-353	1/3	575-3	24V.A.C.	1780.00
ETH-353	1/2	575-3	24V.A.C.	1810.00
ETH-353	3/4	575-3	24V.A.C.	1840.00
ETH-353	1	575-3	24V.A.C.	1870.00

## TROLLEY TYPE INDUSTRIAL ELECTRIC DOOR OPERATOR WITH DC2000 DEDICATED LOGIC CONTROLLER

MODIFICATIONS: PRICE

Additional control circuit for 115V AC available at no extra charge.

DOORS OVER 14' HIGH (for each additional foot) add to net price.....25.50

REVERSE MOUNT - used for limited backroom 3' plus door height (see drawing 3019) (part no. 50160) ..... 405.00

FOR HIGH-CYCLE OPERATION:  
Cast iron pillow block bearing on final drive, add to net price (part no. 50205).....165.00

Electro mechanical built-in "REVERSE SYSTEM" for single and three phase motors with 1.5 second delay add to net price.....195.00

(This built-in door pressure sensing system eliminated the need for any reversing devices installed at the bottom edge of the door)

NOTE: for proper function door must be properly balanced.

PRICE FOR CONTROLS AND ACCESSORIES see pages 38 to 43.

For additional information see catalogues E105A & E113A.



**DOORLEC CORPORATION**

MANUFACTURERS OF ELECTRIC OPERATORS FOR DOORS, GATES AND TRAFFIC CONTROL, BARRIERS

# MODEL ETHW

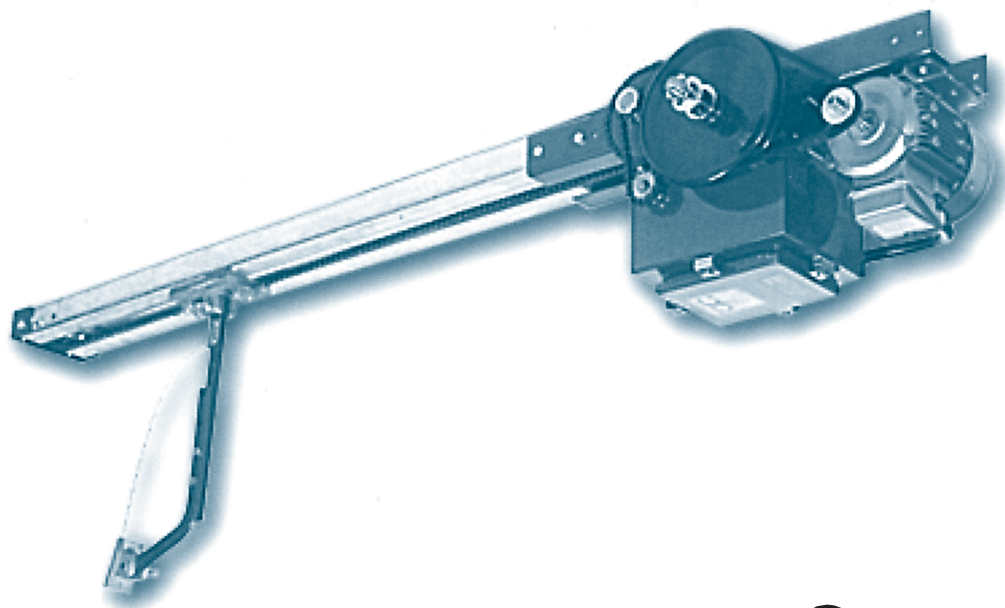

## TROLLEY TYPE INDUSTRIAL ELECTRIC DOOR OPERATOR WITH DC2000 DEDICATED LOGIC CONTROLLER

Watertight/Dust Tight  
EEMAC Type 4  
and Type 12

CANADIAN PATENT NO. 1165785

PRICE FOR CONTROLS AND ACCESSORIES  
See pages 38 to 43 .

For additional information  
see catalogues E112A and E113A.



**DOORLEC  
CORPORATION**

MANUFACTURERS OF ELECTRIC OPERATORS FOR  
DOORS, GATES AND TRAFFIC CONTROL, BARRIERS

### HORSEPOWER SELECTION GUIDE

Motor	Door of wood or aluminium	Fiberglass	Steel door 20 ga.	Maximum door ht.	Unballanced door wt.
1/3 H.P. 249W	288 sq.ft. 27m <sup>2</sup>	320 sq.ft. 30m <sup>2</sup>	224 sq.ft. 27m <sup>2</sup>	24'0" 7,3m	900 lbs. 408 kg.
1/2 H.P. 373W	320 sq.ft. 30m <sup>2</sup>	400 sq.ft. 37m <sup>2</sup>	256 sq.ft. 24m <sup>2</sup>	24'0" 7,3m	800 lbs. 363 kg.
3/4 H.P. 560W	400 sq.ft. 27m <sup>2</sup>	576 sq.ft. 30m <sup>2</sup>	288 sq.ft. 27m <sup>2</sup>	24'0" 7,3m	900 lbs. 408 kg.
1 H.P. 746W	576 sq.ft. 54m <sup>2</sup>	624 sq.ft. 58m <sup>2</sup>	320 sq.ft. 30m <sup>2</sup>	24'0" 7,3m	2000 lbs. 907 kg.

MODEL	H.P.	VOLTAGE- PHASE	CIRCUIT DE CONTRÔLE	RETAIL PRICE
ETHW-311	1/3	115-1	24V.A.C.	2730.00
ETHW-311	1/2	115-1	24V.A.C.	2770.00
ETHW-311	3/4	115-1	24V.A.C.	2820.00
ETHW-321	1/3	230-1	24V.A.C.	2730.00
ETHW-321	1/2	230-1	24V.A.C.	2770.00
ETHW-321	3/4	230-1	24V.A.C.	2820.00
ETHW-383	1/3	208-3	24V.A.C.	2860.00
ETHW-383	1/2	208-3	24V.A.C.	2890.00
ETHW-383	3/4	208-3	24V.A.C.	2930.00
ETHW-383	1	208-3	24V.A.C.	2980.00
ETHW-343	1/3	460-3	24V.A.C.	2860.00
ETHW-343	1/2	460-3	24V.A.C.	2890.00
ETHW-343	3/4	460-3	24V.A.C.	2930.00
ETHW-343	1	460-3	24V.A.C.	2980.00
ETHW-353	1/3	575-3	24V.A.C.	2860.00
ETHW-353	1/2	575-3	24V.A.C.	2890.00
ETHW-353	3/4	575-3	24V.A.C.	2930.00
ETHW-353	1	575-3	24V.A.C.	2980.00

Additional control circuit for 115V AC available at no extra charge.

DOORS OVER 14' HIGH (for each additional foot) add to net price.....25.50

REVERSE MOUNT - used for limited backroom 3 ft. plus door height

(see drawing 3019) (part no . 50160) ..... 405.00

FOR HIGH-CYCLE OPERATION: cast iron pillow block bearing on final drive,

add to net price (part no. 50205).....195.00

# MODEL ETBH



## HORSEPOWER SELECTION GUIDE

Motor	Door of wood or aluminium	Fiberglass	Steel door 20 ga.	Maximum door ht.	Unbalanced door wt.
1/3 H.P. 249W	320 sq.ft. 30m <sup>2</sup>	576 sq.ft. 30m <sup>2</sup>	288 sq.ft. 27m <sup>2</sup>	24'0" 7,3m	1200 lbs. 544 kg.
1/2 H.P. 373W	400 sq.ft. 37m <sup>2</sup>	624 sq.ft. 58m <sup>2</sup>	320 sq.ft. 30m <sup>2</sup>	24'0" 7,3m	1500 lbs. 680 kg.
3/4 H.P. 560W	576 sq.ft. 54m <sup>2</sup>	672 sq.ft. 62m <sup>2</sup>	400 sq.ft. 37m <sup>2</sup>	24'0" 7,3m	2000 lbs. 907 kg.
1 H.P. 746W	625 sq.ft. 58m <sup>2</sup>	720 sq.ft. 67m <sup>2</sup>	576 sq.ft. 54m <sup>2</sup>	24'0" 7,3m	2800 lbs. 1270 kg.

MODEL	H.P.	VOLTAGE-PHASE	CONTROL CIRCUIT	RETAIL PRICE
ETBH-311	1/3	115-1	24V.A.C.	1780.00
ETBH-311	1/2	115-1	24V.A.C.	1830.00
ETBH-311	3/4	115-1	24V.A.C.	1900.00
ETBH-321	1/3	230-1	24V.A.C.	1780.00
ETBH-321	1/2	230-1	24V.A.C.	1830.00
ETBH-321	3/4	230-1	24V.A.C.	1900.00
ETBH-383	1/3	208-3	24V.A.C.	1900.00
ETBH-383	1/2	208-3	24V.A.C.	1930.00
ETBH-383	3/4	208-3	24V.A.C.	1960.00
ETBH-383	1	208-3	24V.A.C.	2000.00
ETBH-343	1/3	460-3	24V.A.C.	1900.00
ETBH-343	1/2	460-3	24V.A.C.	1930.00
ETBH-343	3/4	460-3	24V.A.C.	1960.00
ETBH-343	1	460-3	24V.A.C.	2000.00
ETBH-353	1/3	575-3	24V.A.C.	1900.00
ETBH-353	1/2	575-3	24V.A.C.	1930.00
ETBH-353	3/4	575-3	24V.A.C.	1960.00
ETBH-353	1	575-3	24V.A.C.	2000.00

## TROLLEY TYPE INDUSTRIAL ELECTRIC DOOR OPERATOR WITH DC2000 DEDICATED LOGIC CONTROLLER

Additional control circuit for 115V AC available at no extra charge

DOORS OVER 14' HIGH (for each additional foot) add to net price.....25.50

REVERSE MOUNT - used for limited backroom 3 ft. plus door height (see drawing 3019) Part # 50160 .....405.00

FOR HIGH-CYCLE OPERATION: cast iron pillow block bearing on final drive, add to net prices (part No. 50205).....165.00

Electro-mechanical built-in "REVERSE SYSTEM" for single and three phase motors with 1.5 second delay add to net price.....195.00

(This built-in door pressure sensing system eliminates the need of any reversing devices installed at the bottom edge of door).

Note: for proper function door must be properly balanced.

PRICES FOR CONTROLS AND ACCESSORIES see pages 38 to 43.

For additional information see catalogues E105A and E113A



**DOORLEC CORPORATION**

MANUFACTURERS OF ELECTRIC OPERATORS FOR DOORS, GATES AND TRAFFIC CONTROL, BARRIERS



# MODEL ETBHW

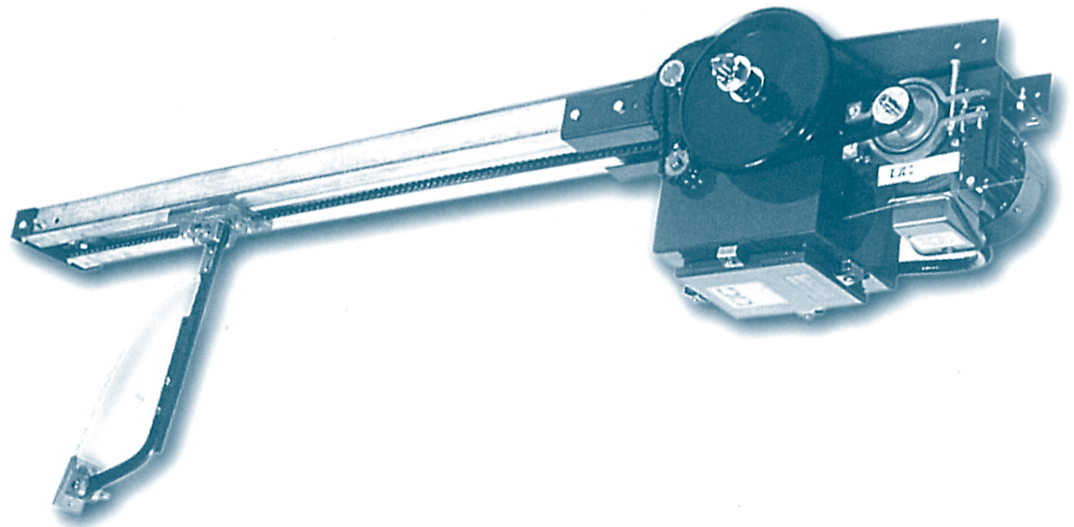

## TROLLEY TYPE INDUSTRIAL ELECTRIC DOOR OPERATOR WITH DC2000 DEDICATED LOGIC CONTROLLER

Watertight/Dust Tight  
EEMAC Type 4  
and Type 12

CANADIAN PATENT NO. 1165785

PRICE FOR CONTROLS AND ACCESSORIES  
see pages 38 to 43.

For additional information  
see catalogues E112 and E113A



**DOORLEC  
CORPORATION**

MANUFACTURERS OF ELECTRIC OPERATORS FOR  
DOORS, GATES AND TRAFFIC CONTROL, BARRIERS

### HORSEPOWER SELECTION GUIDE

Motor	Door of wood or aluminium	Fiberglass	Steel door 20 ga.	Maximum door ht.	Unbalanced door wt.
1/3 H.P. 249W	320 sq.ft. 30m <sup>2</sup>	576 sq.ft. 53m <sup>2</sup>	288 sq.ft. 27m <sup>2</sup>	24'0" 7,3m	1200 lbs. 544 kg.
1/2 H.P. 373W	400 sq.ft. 37m <sup>2</sup>	624 sq.ft. 58m <sup>2</sup>	320 sq.ft. 30m <sup>2</sup>	24'0" 7,3m	1500 lbs. 680 kg.
3/4 H.P. 560W	576 sq.ft. 54m <sup>2</sup>	672 sq.ft. 62m <sup>2</sup>	400 sq.ft. 37m <sup>2</sup>	24'0" 7,3m	2000 lbs. 907 kg.
1 H.P. 746W	625 sq.ft. 58m <sup>2</sup>	720 sq.ft. 67m <sup>2</sup>	576 sq.ft. 54m <sup>2</sup>	24'0" 7,3m	2800 lbs. 1270 kg.

MODEL	H.P.	VOLTAGE-PHASE	CIRCUIT DE CONTRÔLE	RETAIL PRICE
ETBHW-311	1/3	115-1	24V.A.C.	2870.00
ETBHW-311	1/2	115-1	24V.A.C.	2930.00
ETBHW-311	3/4	115-1	24V.A.C.	2990.00
ETBHW-321	1/3	230-1	24V.A.C.	2870.00
ETBHW-321	1/2	230-1	24V.A.C.	2930.00
ETBHW-321	3/4	230-1	24V.A.C.	2990.00
ETBHW-383	1/3	208-3	24V.A.C.	2980.00
ETBHW-383	1/2	208-3	24V.A.C.	3020.00
ETBHW-383	3/4	208-3	24V.A.C.	3060.00
ETBHW-383	1	208-3	24V.A.C.	3090.00
ETBHW-343	1/3	460-3	24V.A.C.	2980.00
ETBHW-343	1/2	460-3	24V.A.C.	3020.00
ETBHW-343	3/4	460-3	24V.A.C.	3060.00
ETBHW-343	1	460-3	24V.A.C.	3090.00
ETBHW-353	1/3	575-3	24V.A.C.	2980.00
ETBHW-353	1/2	575-3	24V.A.C.	3020.00
ETBHW-353	3/4	575-3	24V.A.C.	3060.00
ETBHW-353	1	575-3	24V.A.C.	3090.00

Additional control circuit for 115V AC available at no extra charge.

DOORS OVER 14' HIGH (for each additional foot) add to net price ..... 25.50

REVERSE MOUNT - used for limited backroom 3 ft. plus door height  
(see drawing 3019) (part no. 50160)..... 405.00

FOR HIGH-CYCLE OPERATION: cast iron pillow black bearing on final drive,  
add to net price (part no. 50205).....165.00

# MODEL ETBX



## HORSEPOWER SELECTION GUIDE

Motor	Door of wood or aluminium	Fiberglass	Steel door 20 ga.	Maximum door ht.	Unbalanced door wt.
1/3 H.P. 249W	320 sq.ft. 30m <sup>2</sup>	576 sq.ft. 30m <sup>2</sup>	288 sq.ft. 27m <sup>2</sup>	24'0" 7,3m	1200 lbs. 544 kg.
1/2 H.P. 373W	400 sq.ft. 37m <sup>2</sup>	624 sq.ft. 58m <sup>2</sup>	320 sq.ft. 30m <sup>2</sup>	24'0" 7,3m	1500 lbs. 680 kg.
3/4 H.P. 560W	576 sq.ft. 54m <sup>2</sup>	672 sq.ft. 62m <sup>2</sup>	400 sq.ft. 37m <sup>2</sup>	24'0" 7,3m	2000 lbs. 907 kg.
1 H.P. 746W	625 sq.ft. 58m <sup>2</sup>	720 sq.ft. 67m <sup>2</sup>	576 sq.ft. 54m <sup>2</sup>	24'0" 7,3m	2800 lbs. 1270 kg.

MODEL	H.P.	VOLTAGE-PHASE	CONTROL CIRCUIT	RETAIL PRICE
ETBX-311	1/3	115-1	24V.A.C.	12330.00
ETBX-311	1/2	115-1	24V.A.C.	12470.00
ETBX-311	3/4	115-1	24V.A.C.	12620.00
ETBX-321	1/3	230-1	24V.A.C.	12330.00
ETBX-321	1/2	230-1	24V.A.C.	12470.00
ETBX-321	3/4	230-1	24V.A.C.	12620.00
ETBX-383	1/3	208-3	24V.A.C.	12330.00
ETBX-383	1/2	208-3	24V.A.C.	12470.00
ETBX-383	3/4	208-3	24V.A.C.	12620.00
ETBX-383	1	208-3	24V.A.C.	12910.00
ETBX-343	1/3	460-3	24V.A.C.	12330.00
ETBX-343	1/2	460-3	24V.A.C.	12470.00
ETBX-343	3/4	460-3	24V.A.C.	12620.00
ETBX-343	1	460-3	24V.A.C.	12910.00
ETBX-353	1/3	575-3	24V.A.C.	12330.00
ETBX-353	1/2	575-3	24V.A.C.	12470.00
ETBX-353	3/4	575-3	24V.A.C.	12620.00
ETBX-353	1	575-3	24V.A.C.	12910.00

Additional control circuit for 115V AC available no extra charge  
 DOORS OVER 14' HIGH (for each additional foot) add to net price.....25.50  
 REVERSE MOUNT used for limited backroom 3' plus door height  
 (see drawing 3019) (part no. 50160) ..... 435.00  
 FOR HIGH-CYCLE OPERATION cast iron pillow block bearings on final drive,  
 add to net price (part no. 50205).....195.00

**TROLLEY TYPE  
 INDUSTRIAL AND  
 COMMERCIAL  
 ELECTRIC DOOR  
 OPERATOR  
 WITH DC2000  
 DEDICATED LOGIC  
 CONTROLLER  
 Explosion Proof  
 EEMAC 7 and 9**

CANADIAN PATENT 1165785

PRICE FOR CONTROLS AND ACCESSORIES  
 see pages 38 to 42.  
 For additional information  
 see catalogues E106A and E113A



**DOORLEC  
 CORPORATION**

MANUFACTURERS OF ELECTRIC OPERATORS FOR  
 DOORS, GATES AND TRAFFIC CONTROL, BARRIERS

# MODEL LJ

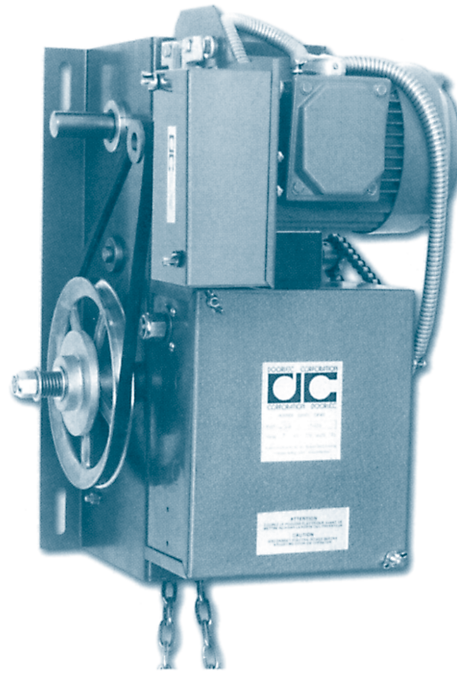

**JACKSHAFT TYPE  
COMMERCIAL  
AND INDUSTRIAL  
ELECTRIC  
DOOR OPERATOR  
WITH DC2000  
DEDICATED LOGIC  
CONTROLLER**

## HORSEPOWER SELECTION GUIDE / Maximum door ht. 18' (5.5m)

Motor	Door of wood or aluminium	Fiberglass	Steel door 20 ga.	Rolling door or grille	Unbalanced door wt.
1/3 H.P. 249W	224 sq.ft. 21m <sup>2</sup>	256 sq.ft. 24m <sup>2</sup>	144 sq.ft. 13,4m <sup>2</sup>	120 sq.ft. 11m <sup>2</sup>	700 lbs. 317 kg.
1/2 H.P. 373W	256 sq.ft. 24m <sup>2</sup>	288 sq.ft. 27m <sup>2</sup>	196 sq.ft. 18m <sup>2</sup>	144 sq.ft. 13,4m <sup>2</sup>	850 lbs. 386 kg.
3/4 H.P. 560W	288 sq.ft. 27m <sup>2</sup>	320 sq.ft. 30m <sup>2</sup>	256 sq.ft. 24m <sup>2</sup>	196 sq.ft. 18m <sup>2</sup>	1000 lbs. 454 kg.
MODEL	H.P.	VOLTAGE-PHASE	CONTROL CIRCUIT	DOOR HEIGHT	RETAIL PRICE
LJ-311	1/3	115-1	24V.A.C.	18'0"	1640.00
LJ-311	1/2	115-1	24V.A.C.	18'0"	1680.00
LJ-311	3/4	115-1	24V.A.C.	18'0"	1740.00
LJ-321	1/3	230-1	24V.A.C.	18'0"	1640.00
LJ-321	1/2	230-1	24V.A.C.	18'0"	1680.00
LJ-321	3/4	230-1	24V.A.C.	18'0"	1740.00
LJ-383	1/3	208-3	24V.A.C.	18'0"	1740.00
LJ-383	1/2	208-3	24V.A.C.	18'0"	1770.00
LJ-383	3/4	208-3	24V.A.C.	18'0"	1800.00
LJ-343	1/3	460-3	24V.A.C.	18'0"	1740.00
LJ-343	1/2	460-3	24V.A.C.	18'0"	1770.00
LJ-343	3/4	460-3	24V.A.C.	18'0"	1800.00
LJ-353	1/3	575-3	24V.A.C.	18'0"	1740.00
LJ-353	1/2	575-3	24V.A.C.	18'0"	1770.00
LJ-353	3/4	575-3	24V.A.C.	18'0"	1800.00

Additional control circuit for 115V AC available at no extra charge

DOORS OVER 14' HIGH (for each additional foot including high-lift and vertical lift doors)  
add to net price.....10.50

FOR HIGH-CYCLE OPERATION cast iron high-speed flanged bearings on all drives  
add to net price (part no. 50266).....180.00

No. 41 drive chain and sprockets are supplied as standard equipment, for final drive.

PRICE FOR CONTROLS AND ACCESSORIES see pages 38 to 43.

For additional information see catalogues no. E107 A and E113A.

WE ARE NOT RESPONSIBLE FOR CORRECT SPROCKET UNLESS COMPLETE SHAFT INFORMATION IS RECEIVED WITH ORDER.



**DOORLEC  
CORPORATION**

MANUFACTURERS OF ELECTRIC OPERATORS FOR  
DOORS, GATES AND TRAFFIC CONTROL, BARRIERS

# MODEL LJH

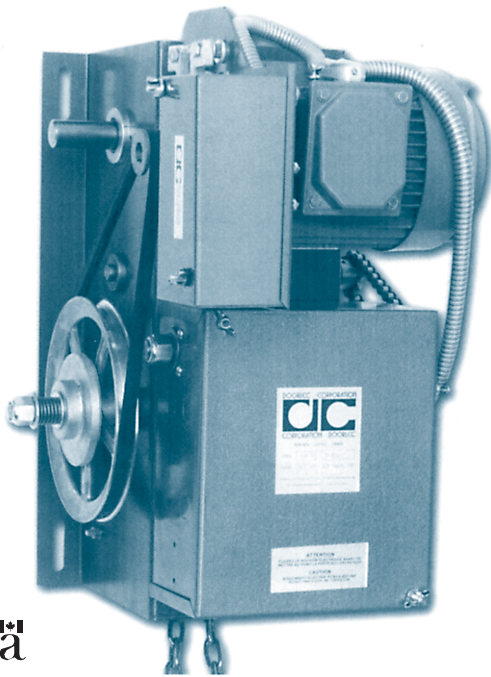

## HORSEPOWER SELECTION GUIDE / Maximum door ht. 18' (5.5m)

Motor	Door of wood or aluminium	Fiberglass	Steel door 20 ga.	Rolling door or grille	Unbalanced door wt.
1/3 H.P. 249W	224 sq.ft. 21m <sup>2</sup>	256 sq.ft. 24m <sup>2</sup>	144 sq.ft. 13,4m <sup>2</sup>	120 sq.ft. 11m <sup>2</sup>	700 lbs. 317 kg.
1/2 H.P. 373W	256 sq.ft. 24m <sup>2</sup>	288 sq.ft. 27m <sup>2</sup>	196 sq.ft. 18m <sup>2</sup>	144 sq.ft. 13,4m <sup>2</sup>	850 lbs. 386 kg.
3/4 H.P. 560W	288 sq.ft. 27m <sup>2</sup>	320 sq.ft. 30m <sup>2</sup>	256 sq.ft. 24m <sup>2</sup>	196 sq.ft. 18m <sup>2</sup>	1000 lbs. 454 kg.
MODEL	H.P.	VOLTAGE-PHASE	CONTROL CIRCUIT	DOOR HEIGHT	RETAIL PRICE
LJH-311	1/3	115-1	24V.A.C.	18'0"	1730.00
LJH-311	1/2	115-1	24V.A.C.	18'0"	1770.00
LJH-311	3/4	115-1	24V.A.C.	18'0"	1810.00
LJH-321	1/3	230-1	24V.A.C.	18'0"	1730.00
LJH-321	1/2	230-1	24V.A.C.	18'0"	1770.00
LJH-321	3/4	230-1	24V.A.C.	18'0"	1810.00
LJH-383	1/3	208-3	24V.A.C.	18'0"	1830.00
LJH-383	1/2	208-3	24V.A.C.	18'0"	1860.00
LJH-383	3/4	208-3	24V.A.C.	18'0"	1890.00
LJH-343	1/3	460-3	24V.A.C.	18'0"	1830.00
LJH-343	1/2	460-3	24V.A.C.	18'0"	1860.00
LJH-343	3/4	460-3	24V.A.C.	18'0"	1890.00
LJH-353	1/3	575-3	24V.A.C.	18'0"	1830.00
LJH-353	1/2	575-3	24V.A.C.	18'0"	1860.00
LJH-353	3/4	575-3	24V.A.C.	18'0"	1890.00

## JACKSHAFT TYPE COMMERCIAL AND INDUSTRIAL ELECTRIC DOOR OPERATOR WITH DC2000 DEDICATED LOGIC CONTROLLER

WE ARE NOT RESPONSIBLE FOR CORRECT SPROCKET UNLESS COMPLETE SHAFT INFORMATION IS RECEIVED WITH ORDER.

Additional control circuit for 115V AC available at no extra charge  
 DOORS OVER 14' HIGH (for each additional foot including high-lift and vertical lift doors)  
 add to net price ..... 10.50  
 FOR HIGH-CYCLE OPERATION cast iron high-speed flanged bearings on all drives  
 add to net price (part no. 50286).....180.00  
 No. 41 drive chain and sprockets are supplied as standard equipment, for final drive.  
 PRICES FOR CONTROLS AND ACCESSORIES see pages 38 to 43.  
 For additional information see catalogues no. E107 A and E113A.



**DOORLEC  
CORPORATION**

MANUFACTURERS OF ELECTRIC OPERATORS FOR  
DOORS, GATES AND TRAFFIC CONTROL, BARRIERS

# MODEL LJHW

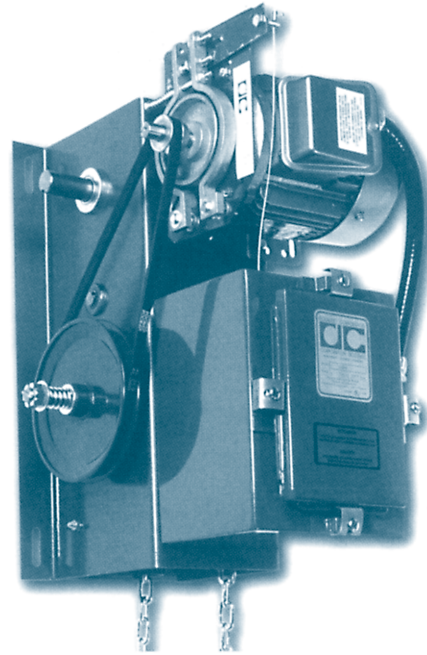

## JACKSHAFT TYPE COMMERCIAL AND INDUSTRIAL ELECTRIC DOOR OPERATOR WITH DC2000 DEDICATED LOGIC CONTROLLER

Watertight/Dust Tight  
EEMAC Type 4  
and Type 12

CANADIAN PATENT NO. 1165785



**DOORLEC  
CORPORATION**

MANUFACTURERS OF ELECTRIC OPERATORS FOR  
DOORS, GATES AND TRAFFIC CONTROL, BARRIERS

### HORSEPOWER SELECTION GUIDE / Maximum door ht. 18' (5.5m)

Motor	Door of wood or aluminium	Fiberglass	Steel door 20 ga.	Rolling door or grille	Unbalanced door wt.
1/3 H.P. 249W	224 sq.ft. 21m <sup>2</sup>	256 sq.ft. 24m <sup>2</sup>	144 sq.ft. 13,4m <sup>2</sup>	120 sq.ft. 11m <sup>2</sup>	700 lbs. 317 kg.
1/2 H.P. 373W	256 sq.ft. 24m <sup>2</sup>	288 sq.ft. 27m <sup>2</sup>	196 sq.ft. 18m <sup>2</sup>	144 sq.ft. 13,4m <sup>2</sup>	850 lbs. 386 kg.
3/4 H.P. 560W	288 sq.ft. 27m <sup>2</sup>	320 sq.ft. 30m <sup>2</sup>	256 sq.ft. 24m <sup>2</sup>	196 sq.ft. 18m <sup>2</sup>	1000 lbs. 454 kg.
MODEL	H.P.	VOLTAGE-PHASE	CONTROL CIRCUIT	DOOR HEIGHT	RETAIL PRICE
LJHW-311	1/3	115-1	24V.A.C.	18'0"	2710.00
LJHW-311	1/2	115-1	24V.A.C.	18'0"	2760.00
LJHW-311	3/4	115-1	24V.A.C.	18'0"	2800.00
LJHW-321	1/3	230-1	24V.A.C.	18'0"	2710.00
LJHW-321	1/2	230-1	24V.A.C.	18'0"	2760.00
LJHW-321	3/4	230-1	24V.A.C.	18'0"	2800.00
LJHW-383	1/3	208-3	24V.A.C.	18'0"	2820.00
LJHW-383	1/2	208-3	24V.A.C.	18'0"	2850.00
LJHW-383	3/4	208-3	24V.A.C.	18'0"	2870.00
LJHW-343	1/3	460-3	24V.A.C.	18'0"	2820.00
LJHW-343	1/2	460-3	24V.A.C.	18'0"	2850.00
LJHW-343	3/4	460-3	24V.A.C.	18'0"	2870.00
LJHW-353	1/3	575-3	24V.A.C.	18'0"	2820.00
LJHW-353	1/2	575-3	24V.A.C.	18'0"	2850.00
LJHW-353	3/4	575-3	24V.A.C.	18'0"	2870.00

Additional control circuit for 115V AC available at no extra charge

DOORS OVER 14' HIGH (for each additional foot including high-lift and vertical lift doors)  
add to net price..... 10.50

FOR HIGH-CYCLE OPERATION cast iron high-speed flanged bearings  
add to net price (part no. 50266)..... 180.00

No. 41 drive chain and sprockets are supplied as standard equipment, for final drive.

PRICES FOR CONTROLS AND ACCESSORIES see pages 38 to 43 .

For additional information see catalogues no. E112 and E113A.

WE ARE NOT RESPONSIBLE FOR CORRECT SPROCKET UNLESS COMPLETE SHAFT INFORMATION IS RECEIVED WITH ORDER.

# MODEL EHJ

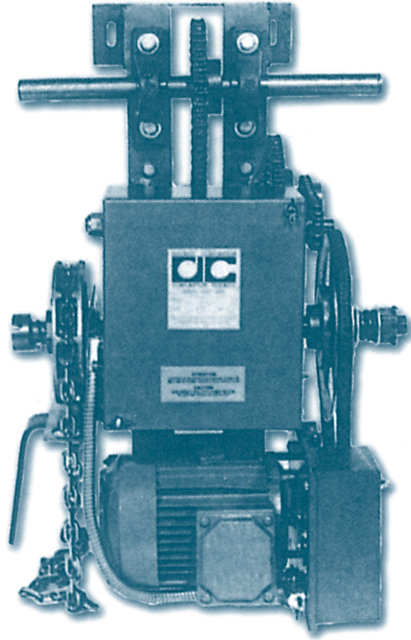

## HORSEPOWER SELECTION GUIDE (no height limitation)

Motor	Door of wood or aluminium	Fiberglass	Steel door 20 ga.	Rolling steel	Unbalanced door wt.
1/3 H.P. 249W	320 sq.ft. 30m <sup>2</sup>	576 sq.ft. 54m <sup>2</sup>	288 sq.ft. 27m <sup>2</sup>	288 sq.ft. 27m <sup>2</sup>	1200 lbs. 544 kg.
1/2 H.P. 373W	400 sq.ft. 37m <sup>2</sup>	624 sq.ft. 58m <sup>2</sup>	320 sq.ft. 30m <sup>2</sup>	320 sq.ft. 30m <sup>2</sup>	1500 lbs. 680 kg.
3/4 H.P. 560W	576 sq.ft. 54m <sup>2</sup>	672 sq.ft. 62m <sup>2</sup>	400 sq.ft. 37m <sup>2</sup>	400 sq.ft. 37m <sup>2</sup>	2000 lbs. 907 kg.
1 H.P. 746W	625 sq.ft. 58m <sup>2</sup>	720 sq.ft. 67m <sup>2</sup>	576 sq.ft. 54m <sup>2</sup>	576 sq.ft. 54m <sup>2</sup>	2800 lbs. 1270 kg.

MODEL	H.P.	VOLTAGE-PHASE	CONTROL CIRCUIT	RETAIL PRICE
EHJ-311	1/3	115-1	24V.A.C.	1930.00
EHJ-311	1/2	115-1	24V.A.C.	1970.00
EHJ-311	3/4	115-1	24V.A.C.	2030.00
EHJ-321	1/3	230-1	24V.A.C.	1930.00
EHJ-321	1/2	230-1	24V.A.C.	1970.00
EHJ-321	3/4	230-1	24V.A.C.	2030.00
EHJ-383	1/3	208-3	24V.A.C.	2030.00
EHJ-383	1/2	208-3	24V.A.C.	2060.00
EHJ-383	3/4	208-3	24V.A.C.	2090.00
EHJ-383	1	208-3	24V.A.C.	2120.00
EHJ-343	1/3	460-3	24V.A.C.	2030.00
EHJ-343	1/2	460-3	24V.A.C.	2060.00
EHJ-343	3/4	460-3	24V.A.C.	2090.00
EHJ-343	1	460-3	24V.A.C.	2120.00
EHJ-353	1/3	575-3	24V.A.C.	2030.00
EHJ-353	1/2	575-3	24V.A.C.	2060.00
EHJ-353	3/4	575-3	24V.A.C.	2090.00
EHJ-353	1	575-3	24V.A.C.	2120.00

Additional control circuit for 115V AC available at no extra charge  
 DOORS OVER 14' HIGH (for each additional foot including high-lift and vertical lift doors)  
 add to net price ..... 10.50  
 No. 40 drive chain and no. 41 sprockets are supplied as standard equipment, for final drive.  
 PRICES FOR CONTROLS AND ACCESSORIES see pages 38 to 43.  
 For additional information see catalogues no. E105A and E113A.

## JACKSHAFT TYPE INDUSTRIAL ELECTRIC DOOR OPERATOR WITH DC2000 DEDICATED LOGIC CONTROLLER

WE ARE NOT RESPONSIBLE FOR CORRECT SPROCKET UNLESS COMPLETE SHAFT INFORMATION IS RECEIVED WITH ORDER.



**DOORLEC  
CORPORATION**

MANUFACTURERS OF ELECTRIC OPERATORS FOR  
DOORS, GATES AND TRAFFIC CONTROL, BARRIERS

# MODEL EHJW

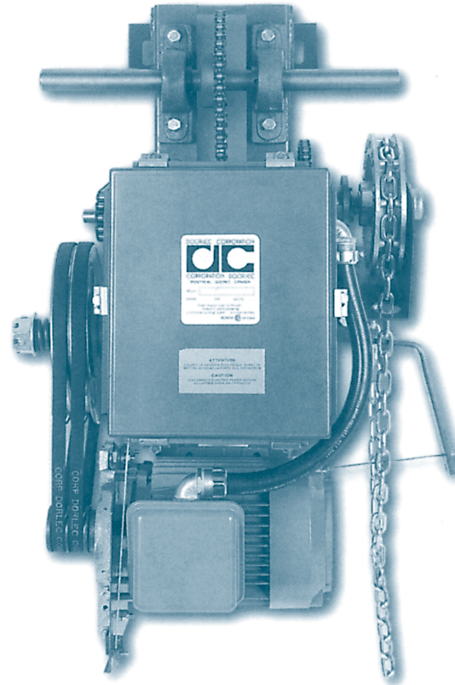

## JACKSHAFT TYPE INDUSTRIAL ELECTRIC DOOR OPERATOR WITH DC2000 DEDICATED LOGIC CONTROLLER

Watertight/Dust Tight  
EEMAC Type 4  
and Type 12

CANADIAN PATENT NO. 1165785

WE ARE NOT RESPONSIBLE FOR CORRECT  
SPROCKET UNLESS COMPLETE SHAFT  
INFORMATION IS RECEIVED WITH ORDER.



**DOORLEC  
CORPORATION**

MANUFACTURERS OF ELECTRIC OPERATORS FOR  
DOORS, GATES AND TRAFFIC CONTROL, BARRIERS

### HORSEPOWER SELECTION GUIDE (no height limitation)

Motor	Door of wood or aluminium	Fiberglass	Steel door 20 ga.	Rolling steel	Unballanced door wt.
1/3 H.P. 249W	320 sq.ft. 30m <sup>2</sup>	576 sq.ft. 54m <sup>2</sup>	288 sq.ft. 27m <sup>2</sup>	288 sq.ft. 27m <sup>2</sup>	1200 lbs. 544 kg.
1/2 H.P. 373W	400 sq.ft. 37m <sup>2</sup>	624 sq.ft. 58m <sup>2</sup>	320 sq.ft. 30m <sup>2</sup>	320 sq.ft. 30m <sup>2</sup>	1500 lbs. 680 kg.
3/4 H.P. 560W	576 sq.ft. 54m <sup>2</sup>	672 sq.ft. 62m <sup>2</sup>	400 sq.ft. 37m <sup>2</sup>	400 sq.ft. 37m <sup>2</sup>	2000 lbs. 907 kg.
1 H.P. 746W	624 sq.ft. 58m <sup>2</sup>	720 sq.ft. 67m <sup>2</sup>	576 sq.ft. 54m <sup>2</sup>	576 sq. ca 54m <sup>2</sup>	2800 lbs. 1270 kg.

MODEL	H.P.	VOLTAGE-PHASE	CONTROL CIRCUIT	RETAIL PRICE
EHJW-311	1/3	115-1	24V.A.C.	2850.00
EHJW-311	1/2	115-1	24V.A.C.	2890.00
EHJW-311	3/4	115-1	24V.A.C.	2930.00
EHJW-321	1/3	230-1	24V.A.C.	2850.00
EHJW-321	1/2	230-1	24V.A.C.	2890.00
EHJW-321	3/4	230-1	24V.A.C.	2930.00
EHJW-383	1/3	208-3	24V.A.C.	2930.00
EHJW-383	1/2	208-3	24V.A.C.	2960.00
EHJW-383	3/4	208-3	24V.A.C.	2990.00
EHJW-383	1	208-3	24V.A.C.	3020.00
EHJW-343	1/3	460-3	24V.A.C.	2930.00
EHJW-343	1/2	460-3	24V.A.C.	2960.00
EHJW-343	3/4	460-3	24V.A.C.	2990.00
EHJW-343	1	460-3	24V.A.C.	3020.00
EHJW-353'	1/3	575-3	24V.A.C.	2930.00
EHJW-353	1/2	575-3	24V.A.C.	2960.00
EHJW-353	3/4	575-3	24V.A.C.	2990.00
EHJW-353	1	575-3	24V.A.C.	2150.00

Additional control circuit for 115V AC available at no extra charge  
DOORS OVER 14' HIGH (for each additional foot including high-lift and vertical lift doors)  
add to net price..... 10.50  
No. 40 drive chain and no. 41 sprockets are supplied as standard equipment, for final drive.  
PRICES FOR CONTROLS AND ACCESSORIES see pages 38 to 43.  
For additional information see catalogues no. E106A and E113A .

# MODEL EHJX

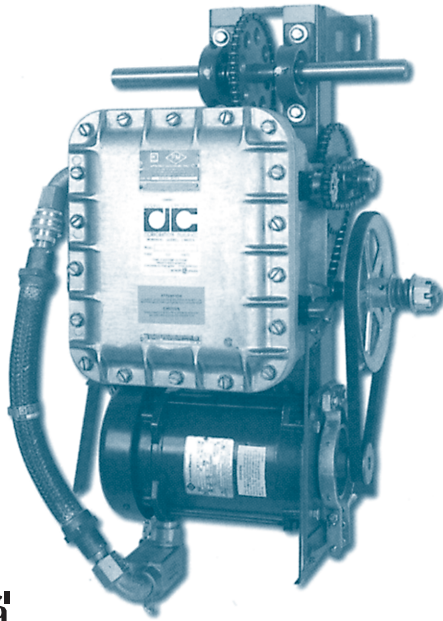

## HORSEPOWER SELECTION GUIDE (no height limitation)

Motor	Door of wood or aluminium	Fiberglass	Steel door 20 ga.	Rolling steel	Unballanced door wt.
1/3 H.P. 249W	320 sq.ft. 30m <sup>2</sup>	576 sq.ft. 54m <sup>2</sup>	288 sq.ft. 27m <sup>2</sup>	288 sq.ft. 27m <sup>2</sup>	1200 lbs. 544 kg.
1/2 H.P. 373W	400 sq.ft. 37m <sup>2</sup>	624 sq.ft. 58m <sup>2</sup>	320 sq.ft. 30m <sup>2</sup>	320 sq.ft. 30m <sup>2</sup>	1500 lbs. 680 kg.
3/4 H.P. 560W	576 sq.ft. 54m <sup>2</sup>	672 sq.ft. 62m <sup>2</sup>	400 sq.ft. 37m <sup>2</sup>	400 sq.ft. 37m <sup>2</sup>	2000 lbs. 907 kg.
1 H.P. 746W	624 sq.ft. 58m <sup>2</sup>	720 sq.ft. 67m <sup>2</sup>	576 sq.ft. 54m <sup>2</sup>	576 sq.ft. 54m <sup>2</sup>	2800 lbs. 1270 kg.

MODEL	H.P.	VOLTAGE-PHASE	CONTROL CIRCUIT	RETAIL PRICE
EHJX-311	1/3	115-1	24V.A.C.	12400.00
EHJX-311	1/2	115-1	24V.A.C.	12550.00
EHJX-311	3/4	115-1	24V.A.C.	12690.00
EHJX-321	1/3	230-1	24V.A.C.	12400.00
EHJX-321	1/2	230-1	24V.A.C.	12550.00
EHJX-321	3/4	230-1	24V.A.C.	12690.00
EHJX-383	1/3	208-3	24V.A.C.	12400.00
EHJX-383	1/2	208-3	24V.A.C.	12550.00
EHJX-383	3/4	208-3	24V.A.C.	12690.00
EHJX-383	1	208-3	24V.A.C.	12980.00
EHJX-343	1/3	460-3	24V.A.C.	12400.00
EHJX-343	1/2	460-3	24V.A.C.	12550.00
EHJX-343	3/4	460-3	24V.A.C.	12690.00
EHJX-343	1	460-3	24V.A.C.	12980.00
EHJX-353	1/3	575-3	24V.A.C.	12400.00
EHJX-353	1/2	575-3	24V.A.C.	12550.00
EHJX-353	3/4	575-3	24V.A.C.	12690.00
EHJX-353	1	575-3	24V.A.C.	12980.00

Additional control circuit for 115V AC available at no extra charge  
 DOORS OVER 14' HIGH (for each additional foot including high-lift and vertical lift doors)  
 add to net price..... 10.50  
 No. 40 drive chain and no. 41 sprockets are supplied as standard equipment, for final drive.  
 PRICES FOR CONTROLS AND ACCESSORIES see pages 38 to 43.  
 For additional information see catalogues no. E106A and E113A.

## JACKSHAFT TYPE INDUSTRIAL AND COMMERCIAL ELECTRIC DOOR OPERATOR WITH DC2000 DEDICATED LOGIC CONTROLLER

### Explosion Proof EEMAC 7 and 9

CANADIAN PATENT NO. 1165785

WE ARE NOT RESPONSIBLE FOR CORRECT  
 SPROCKET UNLESS COMPLETE SHAFT  
 INFORMATION IS RECEIVED WITH ORDER.



## DOORLEC CORPORATION

MANUFACTURERS OF ELECTRIC OPERATORS FOR  
 DOORS, GATES AND TRAFFIC CONTROL, BARRIERS



# MODEL GT

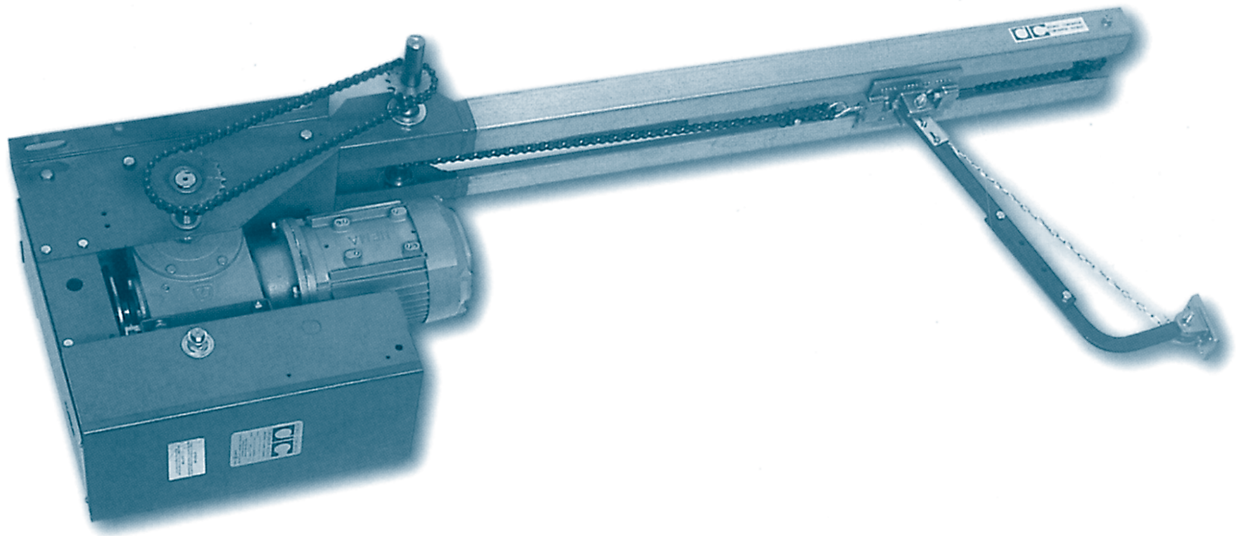

## WORM-GEAR TROLLEY TYPE INDUSTRIAL ELECTRIC DOOR OPERATOR WITH DC2000 DEDICATED LOGIC CONTROLLER

PRICE

Additional control circuit for 115 AC available at no extra charge.

ADJUSTABLE TORQUE LIMITER  
Part no. 50170..... 885.00  
DOORS OVER 14' HIGH (for each additional foot)  
add to net price..... 25.50  
RC40 chain in lieu of RC41  
add to net price for each foot.....12.00  
PRICE FOR CONTROLS AND ACCESSORIES  
see pages 38 to 43.  
For additional information  
see catalogues E106A and E113A.



**DOORLEC  
CORPORATION**

MANUFACTURERS OF ELECTRIC OPERATORS FOR  
DOORS, GATES AND TRAFFIC CONTROL, BARRIERS

### HORSEPOWER SELECTION GUIDE / MAX. SQ. FT. AREA

Motor	WEIGHT COUNTER-BALANCE DOORS	TORSION SPRING COUNTER-BALANCE DOORS		
	OVERHEAD TYPE	WOOD	ALUMINIUM	STEEL 16 GA.
¾ H.P. 650W	320 sq.ft. 30m <sup>2</sup>	420 sq.ft. 39m <sup>2</sup>	420 sq.ft. 39m <sup>2</sup>	260 sq.ft. 24m <sup>2</sup>
1 H.P. 746W	420 sq.ft. 39m <sup>2</sup>	530 sq.ft. 49m <sup>2</sup>	530 sq.ft. 49m <sup>2</sup>	320 sq.ft. 30m <sup>2</sup>
1 ½ H.P. 1119W	560 sq.ft. 52m <sup>2</sup>	-	-	460 sq.ft. 43m <sup>2</sup>
2 H.P. 1493W	-	-	-	540 sq.ft. 50m <sup>2</sup>
Weight/Area calculations.	2.5 lb / sq.ft. 12.23 kg / m <sup>2</sup>	2.45 lb / sq.ft. 11.99 kg / m <sup>2</sup>	2.25 lb / sq.ft. 11.01 kg / m <sup>2</sup>	4.25 lb / sq.ft. 20.79 kg / m <sup>2</sup>

Additional weight/area for glass

D.D. (24 oz. ¼" wired ⅜" acrylic

1.62 lb. / sq.ft. (7.93 kg / m<sup>2</sup>)  
3.27 lb. / sq.ft. (16.00 kg / m<sup>2</sup>)  
1.54 lb. / sq.ft. (7.53 kg / m<sup>2</sup>)

NOTE: The horsepower to door size and weight ratio is a general guideline only and is based on proper door balance. Variations from the norm will affect the recommended horsepower. Please consult factory.

MODEL	H.P.	VOLTAGE-PHASE	CONTROL CIRCUIT	RETAIL PRICE
GT-311	¾	115-1	24V.A.C.	2860.00
GT-311	1	115-1	24V.A.C.	2930.00
GT-311	1½	115-1	24V.A.C.	3030.00
GT-321	¾	230-1	24V.A.C.	2860.00
GT-321	1	230-1	24V.A.C.	2930.00
GT-321	1½	230-1	24V.A.C.	3030.00
GT-383	¾	208-3	24V.A.C.	2860.00
GT-383	1	208-3	24V.A.C.	2930.00
GT-383	1½	208-3	24V.A.C.	3030.00
GT-383	2	208-3	24V.A.C.	3540.00
GT-343	¾	460-3	24V.A.C.	2860.00
GT-343	1	460-3	24V.A.C.	2930.00
GT-343	1½	460-3	24V.A.C.	3030.00
GT-343	2	460-3	24V.A.C.	3540.00
GT-353	¾	575-3	24V.A.C.	2860.00
GT-353	1	575-3	24V.A.C.	2930.00
GT-353	1½	575-3	24V.A.C.	3030.00
GT-353	2	575-3	24V.A.C.	3540.00

# MODEL GTW



## HORSEPOWER SELECTION GUIDE / MAX. SQ. FT. AREA

Motor	WEIGHT COUNTER-BALANCE DOORS	TORSION SPRING COUNTER-BALANCE DOORS		
	OVERHEAD TYPE	WOOD	ALUMINIUM	STEEL 16 GA.
¾ H.P. 650W	320 sq.ft. 30m <sup>2</sup>	420 sq.ft. 39m <sup>2</sup>	420 sq.ft. 39m <sup>2</sup>	260 sq.ft. 24m <sup>2</sup>
1 H.P. 746W	420 sq.ft. 39m <sup>2</sup>	530 sq.ft. 49m <sup>2</sup>	530 sq. ca 49m <sup>2</sup>	320 sq.ft. 30m <sup>2</sup>
1 ½ H.P. 1119W	560 sq.ft. 52m <sup>2</sup>	-	-	460 sq.ft. 43m <sup>2</sup>
2 H.P. 1493W	-	-	-	540 sq.ft. 50m <sup>2</sup>
Weight/Area calculations	2.5 lb / sq.ft. 12.23 kg / m <sup>2</sup>	2.45 lb / sq.ft. 11.99 kg / m <sup>2</sup>	2.25 lb / sq.ft. 11.01 kg / m <sup>2</sup>	4.25 lb / sq.ft. 20.79 kg / m <sup>2</sup>

Additional weight/area for glass D.D. (24 oz. ¼" wired ¾" acrylic) 1.62 lb. / sq.ft. (7.93 kg / m<sup>2</sup>)  
3.27 lb. / sq.ft. (16.00 kg / m<sup>2</sup>)  
1.54 lb. / sq.ft. (7.53 kg / m<sup>2</sup>)

NOTE: The horsepower to door size and weight ratio is a general guideline only and is based on proper door balance. Variations from the norm will affect the recommended horsepower. Please consult factory.

MODEL	H.P.	VOLTAGE-PHASE	CONTROL CIRCUIT	RETAIL PRICE
GTW-311	¾	115-1	24V.A.C.	4170.00
GTW-311	1	115-1	24V.A.C.	4240.00
GTW-311	1½	115-1	24V.A.C.	4320.00
GTW-321	¾	230-1	24V.A.C.	4170.00
GTW-321	1	230-1	24V.A.C.	4240.00
GTW-321	1½	230-1	24V.A.C.	4320.00
GTW-383	¾	208-3	24V.A.C.	4170.00
GTW-383	1	208-3	24V.A.C.	4240.00
GTW-383	1½	208-3	24V.A.C.	4320.00
GTW-383	2	208-3	24V.A.C.	4680.00
GTW-343	¾	460-3	24V.A.C.	4170.00
GTW-343	1	460-3	24V.A.C.	4240.00
GTW-343	1½	460-3	24V.A.C.	4320.00
GTW-343	2	460-3	24V.A.C.	4680.00
GTW-353	¾	575-3	24V.A.C.	4170.00
GTW-353	1	575-3	24V.A.C.	4240.00
GTW353	1½	575-3	24V.A.C.	4320.00
GTW-353	2	575-3	24V.A.C.	4680.00

**WORM-GEAR  
TROLLEY TYPE  
INDUSTRIAL  
ELECTRIC DOOR OPERATOR  
WITH DC2000 DEDICATED  
LOGIC CONTROLLER  
Watertight/Dust Tight  
EEMAC Type 4 and Type 12**

CANADIAN PATENT NO. 1165785

PRICE

Additional control circuit for 115V AC available at no extra charge .

ADJUSTABLE TORQUE LIMITER

Part no. 50171..... 885.00

RC40 chain in lieu of RC41

add to net price for each foot.....12.00

DOORS OVER 14' HIGH (for each additional foot)

add to net price ..... 25.50

PRICE FOR CONTROLS AND ACCESSORIES

see pages 38 to 43.

For additional information

see catalogues E112 and E113A.



**DOORLEC  
CORPORATION**

MANUFACTURERS OF ELECTRIC OPERATORS FOR  
DOORS, GATES AND TRAFFIC CONTROL, BARRIERS



**WORM-GEAR  
TROLLEY TYPE  
INDUSTRIAL  
ELECTRIC DOOR  
OPERATOR WITH DC2000  
DEDICATED LOGIC  
CONTROLLER  
Explosion Proof  
EEMAC 7 and 9**

CANADIAN PATENT NO. 1165785  
PRICE

Additional control circuit for 115V AC  
available at no extra charge.  
ADJUSTABLE TORQUE LIMITER  
Part no. 50170..... 825.00  
RC40 chain in lieu of RC41  
add to net price for each foot..... 12.00  
DOORS OVER 14' HIGH (for each additional foot)  
add to net price..... 25.50  
PRICE FOR CONTROLS AND ACCESSORIES  
see pages 38 to 43.  
For additional information see  
catalogues E106A and E113A.



**DOORLEC  
CORPORATION**

MANUFACTURERS OF ELECTRIC OPERATORS FOR  
DOORS, GATES AND TRAFFIC CONTROL, BARRIERS

## HORSEPOWER SELECTION GUIDE / MAX. SQ. FT. AREA

Motor	WEIGHT COUNTER- BALANCE DOORS	TORSION SPRING COUNTER-BALANCE DOORS		
	OVERHEAD TYPE	WOOD	ALUMINIUM	STEEL 16 GA.
¾ H.P. 650W	320 sq.ft. 30m <sup>2</sup>	420 sq.ft. 39m <sup>2</sup>	420 sq.ft. 39m <sup>2</sup>	260 sq.ft. 24m <sup>2</sup>
1 H.P. 746W	420 sq.ft. 39m <sup>2</sup>	530 sq.ft. 49m <sup>2</sup>	530 sq.ft. 49m <sup>2</sup>	320 sq.ft. 30m <sup>2</sup>
1 ½ H.P. 1119W	560 sq.ft. 52m <sup>2</sup>	-	-	460 sq.ft. 43m <sup>2</sup>
2 H.P. 1493W	-	-	-	540 sq.ft. 50m <sup>2</sup>
Weight/Area calculations	2.5 lb / sq.ft. 12.23 kg / m <sup>2</sup>	2.45 lb / sq.ft. 11.99 kg / m <sup>2</sup>	2.25 lb / sq.ft. 11.01 kg / m <sup>2</sup>	4.25 lb / sq.ft. 20.79 kg / m <sup>2</sup>

Additional weight/area for glass  
D.D. (24 oz. ¼" wired ¾" acrylic)  
1.62 lb. / sq.ft. (7.93 kg / m<sup>2</sup>)  
3.27 lb. / sq.ft. (16.00 kg / m<sup>2</sup>)  
1.54 lb. / sq.ft. (7.53 kg / m<sup>2</sup>)

NOTE: The horsepower to door size and weight ratio is a general guideline only and is based on proper door balance. Variations from the norm will affect the recommended horsepower. Please consult factory.

MODEL	H.P.	VOLTAGE- PHASE	CONTROL CIRCUIT	RETAIL PRICE
GTX-311	¾	115-1	24V.A.C.	13570.00
GTX-311	1	115-1	24V.A.C.	13710.00
GTX-311	1½	115-1	24V.A.C.	13860.00
GTX-321	¾	230-1	24V.A.C.	13570.00
GTX-321	1	230-1	24V.A.C.	13710.00
GTX-321	1½	230-1	24V.A.C.	13860.00
GTX-383	¾	208-3	24V.A.C.	13570.00
GTX-383	1	208-3	24V.A.C.	13710.00
GTX-383	1½	208-3	24V.A.C.	13860.00
GTX-383	2	208-3	24V.A.C.	14220.00
GTX-343	¾	460-3	24V.A.C.	13570.00
GTX-343	1	460-3	24V.A.C.	13710.00
GTX-343	1½	460-3	24V.A.C.	13860.00
GTX-343	2	460-3	24V.A.C.	14220.00
GTX-353	¾	575-3	24V.A.C.	13570.00
GTX-353	1	575-3	24V.A.C.	13710.00
GTX-353	1½	575-3	24V.A.C.	13860.00
GTX-353	2	575-3	24V.A.C.	14220.00

# MODEL GH

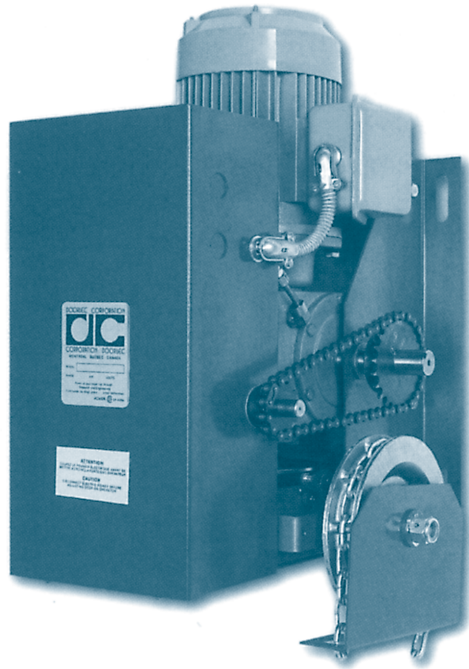

## HORSEPOWER SELECTION GUIDE / MAX. SQ. FT. AREA

Motor	ROLLING DOORS				WEIGHT COUNTER-BALANCE DOORS		TORSION SPRING COUNTER-BALANCE DOORS		
	STEEL SERVICE DOORS	ALUMINUM SERVICE DOORS	STEEL GRILLES	ALUMINUM GRILLES	OVER-HEAD TYPE	VERTICAL TYPE STEEL	WOOD	ALUMINUM	STEEL 16 GA.
¾ H.P. 650W	270 sq.ft. 325m²	430 sq.ft. 40m²	320 sq.ft. 30m²	450 sq.ft. 42m²	320 sq.ft. 30m²	230 sq.ft. 21m²	420 sq.ft. 39m²	420 sq.ft. 39m²	260 sq.ft. 24m²
1 H.P. 746W	310 sq.ft. 29m²	600 sq.ft. 56m²	420 sq.ft. 39m²	640 sq.ft. 60m²	420 sq.ft. 39m²	300 sq.ft. 28m²	520 sq.ft. 48m²	520 sq.ft. 48m²	320 sq.ft. 30m²
1 ½ H.P. 1119W	420 sq.ft. 39m²	-	620 sq.ft. 58m²	-	560 sq.ft. 52m²	410 sq.ft. 38m²	-	-	460 sq.ft. 43m²
2 H.P. 1493W	560 sq.ft. 52m²	-	-	-	-	510 sq.ft. 47m²	-	-	540 sq.ft. ca 50m²
Weight/Area calculation	4 lb / sq.ft. 19.57 kg / m²	2.25 lb / sq.ft. 11.01 kg / m²	2.95 lb / sq.ft. 14.43 kg / m²	1.95 lb / sq.ft. 9.54 kg / m²	2.5 lb / sq.ft. 12.23 kg / m²	5.5 lb / sq.ft. 26.91 kg / m²	2.45 lb / sq.ft. 11.99 kg / m²	2.25 lb / sq.ft. 11.01 kg / m²	4.25 lb / sq.ft. 20.79 kg / m²

Per sq.ft. weight additions for glass D.D. 24 oz. 1.62 lb. / sq.ft. (7.93 kg / m²)  
 ¼" wired 3.27 lb. / sq.ft. (16.00 kg / m²)  
 ⅜" acrylic 1.54 lb. / sq.ft. (7.53 kg / m²)

NOTE: The horsepower to door size and weight ratio is a general guideline only and is based on proper door balance. Variations from the norm will affect the recommended horsepower. Please consult factory.

MODEL	H.P.	VOLTAGE-PHASE	CONTROL CIRCUIT	RETAIL PRICE
GH-311	¾	115-1	24V.A.C.	2600.00
GH-311	1	115-1	24V.A.C.	2670.00
GH-311	1½	115-1	24V.A.C.	2740.00
GH-321	¾	230-1	24V.A.C.	2600.00
GH-321	1	230-1	24V.A.C.	2670.00
GH-321	1½	230-1	24V.A.C.	2740.00
GH-383	¾	208-3	24V.A.C.	2600.00
GH-383	1	208-3	24V.A.C.	2670.00
GH-383	1½	208-3	24V.A.C.	2740.00
GH-383	2	208-3	24V.A.C.	3060.00
GH-343	¾	460-3	24V.A.C.	2600.00
GH-343	1	460-3	24V.A.C.	2670.00
GH-343	1½	460-3	24V.A.C.	2740.00
GH-343	2	460-3	24V.A.C.	3060.00
GH-353	¾	575-3	24V.A.C.	2600.00
GH-353	1	575-3	24V.A.C.	2670.00
GH-353	1½	575-3	24V.A.C.	2740.00
GH-353	2	575-3	24V.A.C.	3060.00

## WORM-GEAR JACKSHAFT TYPE INDUSTRIAL ELECTRIC DOOR OPERATOR WITH DC2000 DEDICATED LOGIC CONTROLLER

PRICE

Additional control circuit for 115V AC available at no extra charge.

ADJUSTABLE TORQUE LIMITER

Part no. 50170 ..... 885.00

DOORS OVER 14' HIGH (for each additional foot) add to net price.....10.50

No. 50 drive chain and sprockets are supplied as standard equipment, for final drive .

PRICE FOR CONTROLS AND ACCESSORIES see pages 38 to 43.

For additional information see catalogues

E106Aand E113A.

WE ARE NOT RESPONSIBLE FOR CORRECT SPROCKET UNLESS COMPLETE SHAFT INFORMATION IS RECEIVED WITH ORDER



**DOORLEC CORPORATION**

MANUFACTURERS OF ELECTRIC OPERATORS FOR DOORS, GATES AND TRAFFIC CONTROL, BARRIERS

# MODEL GHW



**WORM-GEAR  
JACKSHAFT TYPE  
INDUSTRIAL ELECTRIC  
DOOR OPERATOR  
WITH DC2000  
DEDICATED LOGIC  
CONTROLLER  
Watertight/Dust Tight  
EEMAC Type 4 and Type 12**

CANADIAN PATENT NO. 1165785

Additional control circuit for 115V AC available at no extra charge .  
ADJUSTABLE TORQUE LIMITER  
Part no. 50170 ..... 885.00  
DOORS OVER 14' HIGH  
(for each additional foot)  
add to net price ..... 10.50  
No. 50 drive chain and sprockets are supplied as standard equipment, for final drive.  
PRICE FOR CONTROLS AND ACCESSORIES see pages 38 to 43.  
For additional information see catalogues no. E106A and E113A.

WE ARE NOT RESPONSIBLE FOR CORRECT SPROCKET UNLESS COMPLETE SHAFT INFORMATION IS RECEIVED WITH ORDER

## HORSEPOWER SELECTION GUIDE / MAX. SQ. FT. AREA

Motor	ROLLING DOORS				WEIGHT COUNTER-BALANCE DOORS		TORSION SPRING COUNTER-BALANCE DOORS		
	STEEL SERVICE DOORS	ALUMINUM SERVICE DOORS	STEEL GRILLES	ALUMINUM GRILLES	OVER-HEAD TYPE	VERTICAL TYPE STEEL	WOOD	ALUMINUM	STEEL 16 GA.
¾H.P. 650W	270 sq.ft. 325m²	430 sq.ft. 40m²	320 sq.ft. 30m²	450 sq.ft. 42m²	320 sq.ft. 30m²	230 sq.ft. 21m²	420 sq.ft. 39m²	420 sq.ft. 39m²	260 sq.ft. 24m²
1 H.P. 746W	310 sq.ft. 29m²	600 sq.ft. 56m²	420 sq.ft. 39m²	640 sq.ft. 60m²	420 sq.ft. 39m²	300 sq.ft. 28m²	520 sq.ft. 48m²	520 sq.ft. 48m²	320 sq.ft. 30m²
1 ½ H.P. 1119W	420 sq.ft. 39m²	-	620 sq.ft. 58m²	-	560 sq.ft. 52m²	410 sq.ft. 38m²	-	-	460 sq.ft. 43m²
2 H.P. 1493W	560 sq.ft. 52m²	-	-	-	-	510 sq.ft. 47m²	-	-	540 sq.ft. 50m²
Weight/Area calculation	4lb / sq.ft. 19.57 kg / m²	2.25 lb / sq.ft. 11.01 kg / m²	2.95 lb / sq.ft. 14.43 kg / m²	1.95 lb / sq.ft. 9.54 kg / m²	2.5 lb / sq.ft. 12.23 kg / m²	5.5 lb / sq.ft. 26.91 kg / m²	2.45 lb / sq.ft. 11.99 kg / m²	2.25 lb / sq.ft. 11.01 kg / m²	4.25 lb / sq.ft. 20.79 kg / m²

Per sq.ft. weight additions for glass D.D. 24 oz. 1.62 lb. / sq.ft. (7.93 kg / m²)  
¼" wired 3.27 lb. / sq.ft. (16.00 kg / m²)  
¾" acrylic 1.54 lb. / sq.ft. (7.53 kg / m²)

NOTE: The horsepower to door size and weight ratio is a general guideline only and is based on proper door balance. Variations from the norm will affect the recommended horsepower. Please consult factory.

MODEL	H.P.	VOLTAGE-PHASE	CONTROL CIRCUIT	RETAIL PRICE
GHW-311	¾	115-1	24V.A.C.	4080.00
GHW-311	1	115-1	24V.A.C.	4160.00
GHW-311	1½	115-1	24V.A.C.	4230.00
GHW-321	¾	230-1	24V.A.C.	4080.00
GHW-321	1	230-1	24V.A.C.	4160.00
GHW-321	1½	230-1	24V.A.C.	4230.00
GHW-383	¾	208-3	24V.C.A.	4080.00
GHW-383	1	208-3	24V.A.C.	4160.00
GHW-383	1½	208-3	24V.A.C.	4230.00
GHW-383	2	208-3	24V.A.C.	4520.00
GHW-343	¾	460-3	24V.A.C.	4080.00
GHW-343	1	460-3	24V.A.C.	4160.00
GHW-343	1½	460-3	24V.A.C.	4230.00
GHW-343	2	460-3	24V.A.C.	4520.00
GHW-353	¾	575-3	24V.A.C.	4080.00
GHW-353	1	575-3	24V.A.C.	4160.00
GHW-353	1½	575-3	24V.A.C.	4230.00
GHW-353	2	575-3	24V.A.C.	4520.00

# MODEL GHX

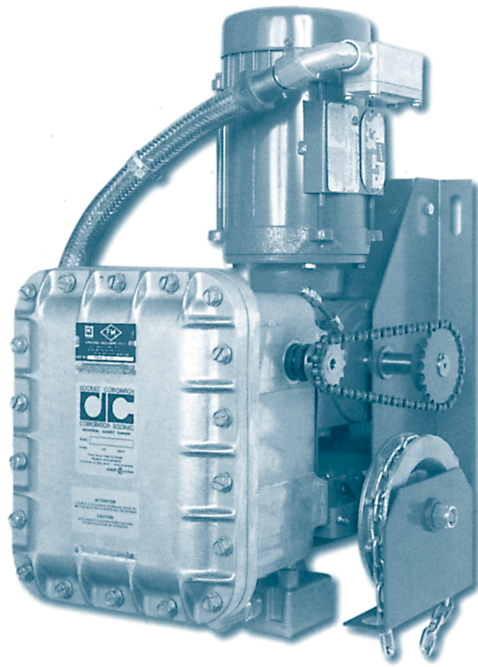

## HORSEPOWER SELECTION GUIDE / MAX. SQ. FT. AREA

Motor	ROLLING DOORS				WEIGHT COUNTER-BALANCE DOORS		TORSION SPRING COUNTER-BALANCE DOORS		
	STEEL SERVICE DOORS	ALUMINUM SERVICE DOORS	STEEL GRILLES	ALUMINUM GRILLES	OVERHEAD TYPE	VERTICAL TYPE STEEL	WOOD	ALUMINUM	STEEL 16 GA.
¾ H.P. 650W	270 sq.ft. 325m²	430 sq.ft. 40m²	320 sq.ft. 30m²	450 sq.ft. 42m²	320 sq.ft. 30m²	230 sq.ft. 21m²	420 sq.ft. 39m²	420 sq.ft. 39m²	260 sq.ft. 24m²
1 H.P. 746W	310 sq.ft. 29m²	600 sq.ft. 56m²	420 sq.ft. 39m²	640 sq.ft. 60m²	420 sq.ft. 39m²	300 sq.ft. 28m²	520 sq.ft. 48m²	520 sq.ft. 48m²	320 sq.ft. 30m²
1 ½ H.P. 1119W	420 sq.ft. 39m²	-	620 sq.ft. 58m²	-	560 sq.ft. 52m²	410 sq.ft. 38m²	-	-	460 sq.ft. 43m²
2 H.P. 1493W	560 sq.ft. 52m²	-	-	-	-	510 sq.ft. 47m²	-	-	540 sq.ft. 50m²
Weight/Area calculation	4 lb / sq.ft. 19.57 kg / m²	2.25 lb / sq.ft. 11.01 kg / m²	2.95 lb / sq.ft. 14.43 kg / m²	1.95 lb / sq.ft. 9.54 kg / m²	2.5 lb / sq.ft. 12.23 kg / m²	5.5 lb / sq.ft. 26.91 kg / m²	2.45 lb / sq.ft. 11.99 kg / m²	2.25 lb / sq.ft. 11.01 kg / m²	4.25 lb / sq.ft. 20.79 kg / m²

Per sq.ft. weight additions for glass  
 D.D. 24 oz. 1.62 lb. / sq.ft. (7.93 kg / m²)  
 ¼" wired 3.27 lb. / sq.ft. (16.00 kg / m²)  
 ¾" acrylic 1.54 lb. / sq.ft. (7.53 kg / m²)

NOTE: The horsepower to door size and weight ratio is a general guideline only and is based on proper door balance. Variations from the norm will affect the recommended horsepower. Please consult factory.

MODEL	H.P.	VOLTAGE-PHASE	CONTROL CIRCUIT	RETAIL PRICE
GHX-311	¾	115-1	24V.A.C.	13350.00
GHX-311	1	115-1	24V.A.C.	13490.00
GHX-311	1½	115-1	24V.A.C.	13640.00
GHX-321	¾	230-1	24V.A.C.	13350.00
GHX-321	1	230-1	24V.A.C.	13490.00
GHX-321	1½	230-1	24V.A.C.	13640.00
GHX-383	¾	208-3	24V.A.C.	13350.00
GHX-383	1	208-3	24V.A.C.	13490.00
GHX-383	1½	208-3	24V.A.C.	13640.00
GHX-383	2	208-3	24V.A.C.	14000.00
GHX-343	¾	460-3	24V.A.C.	13350.00
GHX-343	1	460-3	24V.A.C.	13490.00
GHX-343	1½	460-3	24V.A.C.	13640.00
GHX-343	2	460-3	24V.A.C.	14000.00
GHX-353	¾	575-3	24V.A.C.	13350.00
GHX-353	1	575-3	24V.A.C.	13490.00
GHX-353	1½	575-3	24V.A.C.	13640.00
GHX-353	2	575-3	24V.A.C.	14000.00

## WORM-GEAR JACKSHAFT TYPE INDUSTRIAL ELECTRIC DOOR OPERATOR WITH DC2000 DEDICATED LOGIC CONTROLLER Explosion Proof EEMAC 7 and 9

CANADIAN PATENT NO. 1165785

PRICE

Additional control circuit for 115V AC available at no extra charge.

ADJUSTABLE TORQUE LIMITER

Part no . 50170..... 885.00  
 DOORS OVER 14' HIGH (for each additional foot)

add to net price ..... 10.50

No. 50 drive chain and sprockets are supplied as standard equipment, for final drive.

PRICE FOR CONTROLS AND ACCESSORIES see pages 38 to 43.

For additional information

see catalogues no. E 106A and E 113A.

WE ARE NOT RESPONSIBLE FOR CORRECT SPROCKET UNLESS COMPLETE SHAFT INFORMATION IS RECEIVED WITH ORDER.



**DOORLEC CORPORATION**

MANUFACTURERS OF ELECTRIC OPERATORS FOR DOORS, GATES AND TRAFFIC CONTROL, BARRIERS

# MODEL GH-3

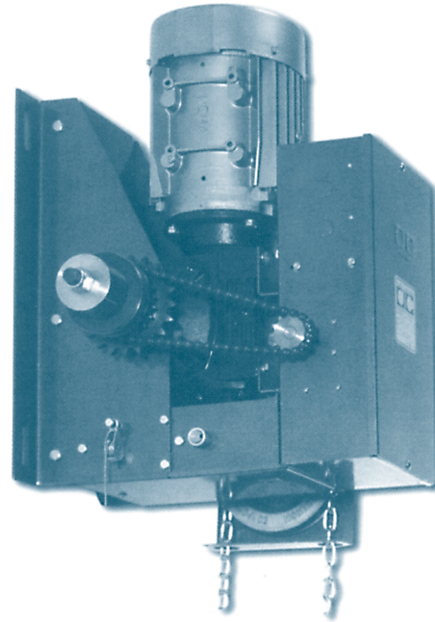

**WORM-GEAR  
JACKSHAFT TYPE  
HEAVY DUTY  
INDUSTRIAL  
ELECTRIC  
DOOR OPERATOR  
WITH DC2000  
DEDICATED LOGIC  
CONTROLLER**

**Max. door size 1600 sq.ft. (149m<sup>2</sup>) / unbalanced weight 6800 lbs (3084 kg)**

MODEL	H.P.	VOLTAGE- PHASE	CONTROL CIRCUIT	RETAIL PRICE
GH-3	3	208-3	24V.A.C.	4590.00
GH-3	3	460-3	24V.A.C.	4590.00
GH-3	3	575-3	24V.A.C.	4590.00

Additional control circuit for 115V AC available at no extra charge.

ADJUSTABLE TORQUE LIMITER Part no . 50175 ..... 1185.00

DOORS OVER 14' HIGH (for each additional foot) add to net price ..... 10.50

Cast-iron flanged high-speed bearings on output shafts in lieu of oilite bushings  
part no. 50226, add to net price ..... 255.00

No. 60 drive chain and sprockets are supplied as standard equipment, for final drive.

PRICE FOR CONTROLS AND ACCESSORIES see pages 38 to 43.

For additional information see catalogues E112 and E113A.

WE ARE NOT RESPONSIBLE FOR CORRECT SPROCKET UNLESS COMPLETE SHAFT INFORMATION IS RECEIVED WITH ORDER.



**DOORLEC  
CORPORATION**

MANUFACTURERS OF ELECTRIC OPERATORS FOR  
DOORS, GATES AND TRAFFIC CONTROL, BARRIERS

# MODEL GHW-3

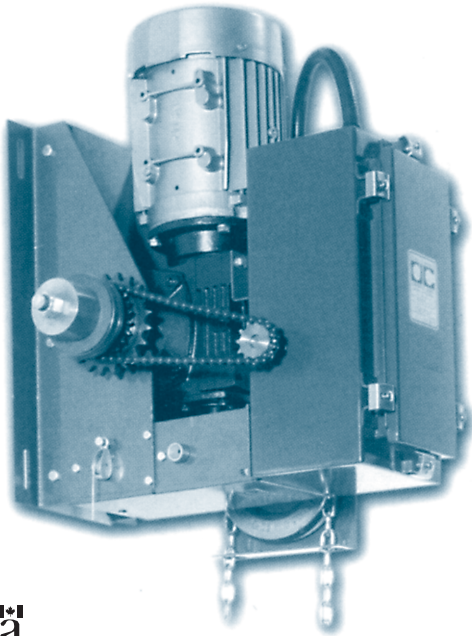

**Max. door size 1600 sq.ft. (149m<sup>2</sup>) / unbalanced weight 6800 lbs (3085 kg)**

MODEL	H.P.	VOLTAGE-PHASE	CONTROL CIRCUIT	RETAIL PRICE
GHW-3	3	208-3	24V.A.C.	5760.00
GHW-3	3	460-3	24V.A.C.	5760.00
GHW-3	3	575-3	24V.A.C.	5760.00

Additional control circuit for 115V AC available at no extra charge.  
 ADJUSTABLE TORQUE LIMITER part no. 50175.....1185.00  
 DOORS OVER 14' HIGH (for each additional foot) add to net price.....10.50  
 Cast-iron flanged high-speed bearings on output shafts in lieu of oilite bushings  
 part no. 50226, add to net price.....255.00  
 No. 60 drive chain and sprockets are supplied as standard equipment, for final drive.  
 PRICE FOR CONTROLS AND ACCESSORIES see pages 38 to 43.  
 For additional information see catalogues E112 and E113A.

WE ARE NOT RESPONSIBLE FOR CORRECT SPROCKET UNLESS COMPLETE SHAFT INFORMATION IS RECEIVED WITH ORDER.

**WORM-GEAR  
 JACKSHAFT TYPE  
 ELECTRIC DOOR  
 OPERATOR  
 WITH DC2000  
 DEDICATED LOGIC  
 CONTROLLER**

**Watertight/Dust Tight  
 EEMAC Type 4 and Type 12**

CANADIAN PATENT NO. 1165785



**DOORLEC  
 CORPORATION**

MANUFACTURERS OF ELECTRIC OPERATORS FOR  
 DOORS, GATES AND TRAFFIC CONTROL, BARRIERS



# MODEL SD

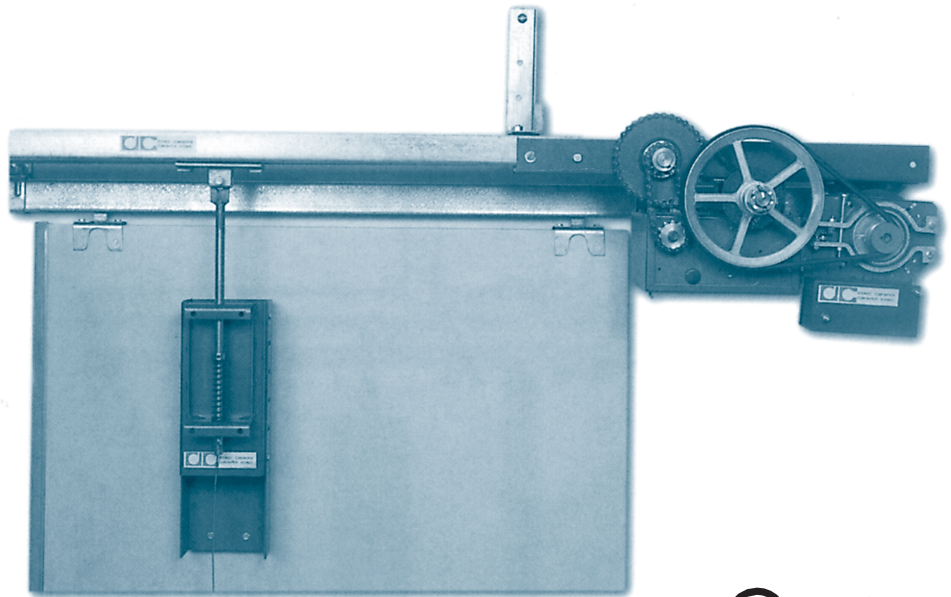

## HORIZONTAL SINGLE SLIDING DOOR ELECTRIC OPERATOR WITH DC2000 DEDICATED LOGIC CONTROLLER

PRICES FOR CONTROLS AND ACCESSORIES  
see pages 38 to 43

For additional information  
see catalogues no. E106A and E113A.

### HORSEPOWER SELECTION GUIDE

Motor Size	Door Area
1/3 H.P. (249W)	200 sq.ft. (18.58m <sup>2</sup> )
1/2 H.P. (373W)	250 sq.ft. (23.22m <sup>2</sup> )
3/4 H.P. (560W)	325 sq.ft. (30.2m <sup>2</sup> )
1 H.P. (746W)	400 sq.ft. (37.16m <sup>2</sup> )

MODEL	H.P.	VOLTAGE-PHASE	CONTROL CIRCUIT	RETAIL PRICE
SD-311	1/3	115-1	24V.A.C.	2770.00
SD-311	1/2	115-1	24V.A.C.	2850.00
SD-311	3/4	115-1	24V.A.C.	2920.00
SD-321	1/3	230-1	24V.A.C.	2770.00
SD-321	1/2	230-1	24V.A.C.	2850.00
SD-321	3/4	230-1	24V.A.C.	2920.00
SD-383	1/3	208-3	24V.A.C.	2930.00
SD-383	1/2	208-3	24V.A.C.	3010.00
SD-383	3/4	208-3	24V.A.C.	3090.00
SD-383	1	208-3	24V.A.C.	3180.00
SD-343	1/3	460-3	24V.A.C.	2930.00
SD-343	1/2	460-3	24V.A.C.	3010.00
SD-343	3/4	460-3	24V.A.C.	3090.00
SD-343	1	460-3	24V.A.C.	3180.00
SD-353	1/3	575-3	24V.A.C.	2930.00
SD-353	1/2	575-3	24V.A.C.	3010.00
SD-353	3/4	575-3	24V.A.C.	3090.00
SD-353	1	575-3	24V.A.C.	3180.00

FIRE RELEASE DOOR ARMS add to net prices..... 255.00

Additional control circuit for 115V AC available at no extra charge .

DOORS OVER 14' WIDE (for each additional foot) add to net price..... 25.50

FOR HIGH-CYCLE OPERATION cast iron high-speed pillow block bearings on final drive  
add to net price (part no. 50205)..... 165.00

Electro-mechanical built-in "REVERSE" system for single and three phase motors  
with 1.5 second delay add to net price..... 195.00

(This built-in pressure sensing system eliminates the need of any reversing devices installed at the bottom edge of door)

Note: for proper function door must be properly balanced.



MANUFACTURERS OF ELECTRIC OPERATORS FOR  
DOORS, GATES AND TRAFFIC CONTROL, BARRIERS

# MODEL BSD

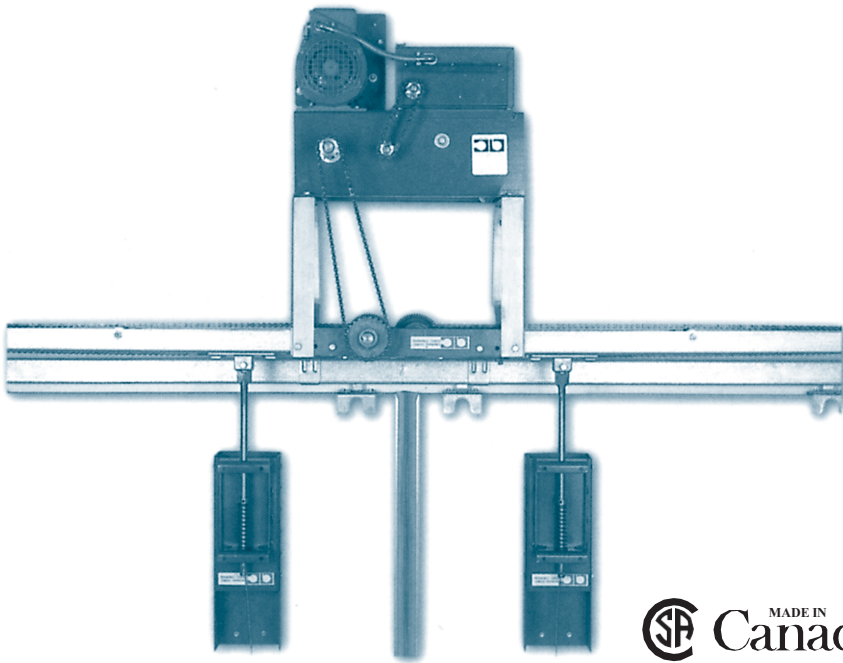

**MADE IN**  
**Canada**

## HORSEPOWER SELECTION GUIDE

Motor Size	Door Area
1/3 H.P. (249W)	200 sq.ft. (18.58m <sup>2</sup> )
1/2 H.P. (373W)	250 sq.ft. (23.22m <sup>2</sup> )
3/4 H.P. (560W)	325 sq.ft. (30.2m <sup>2</sup> )
1 H.P. (746W)	400 sq.ft. (37.16m <sup>2</sup> )

MODEL	H.P.	VOLTAGE-PHASE	CONTROL CIRCUIT	RETAIL PRICE
BSD-311	1/3	115-1	24V.A.C.	3570.00
BSD-311	1/2	115-1	24V.A.C.	3630.00
BSD-311	3/4	115-1	24V.A.C.	3690.00
BSD-321	1/3	230-1	24V.A.C.	3570.00
BSD-321	1/2	230-1	24V.A.C.	3630.00
BSD-321	3/4	230-1	24V.A.C.	3690.00
BSD-383	1/3	208-3	24V.A.C.	3790.00
BSD-383	1/2	208-3	24V.A.C.	3860.00
BSD-383	3/4	208-3	24V.A.C.	3940.00
BSD-383	1	208-3	24V.A.C.	4010.00
BSD-343	1/3	460-3	24V.A.C.	3790.00
BSD-343	1/2	460-3	24V.A.C.	3860.00
BSD-343	3/4	460-3	24V.A.C.	3940.00
BSD-343	1	460-3	24V.A.C.	4010.00
BSD-353	1/3	575-3	24V.A.C.	3790.00
BSD-353	1/2	575-3	24V.A.C.	3860.00
BSD-353	3/4	575-3	24V.A.C.	3940.00
BSD-353	1	575-3	24V.A.C.	4010.00

**HORIZONTAL  
BI-PARTING  
SLIDING  
ELECTRIC DOOR  
OPERATOR  
WITH DC2000  
DEDICATED LOGIC  
CONTROLLER**

PRICE  
FIRE RELEASE DOOR ARMS add to net prices (part no. 50216) .....450.00  
Additional control circuit for 115V AC available at no extra charge .  
DOORS OVER 14' WIDE (for each additional foot) add to net price.....25.50  
FOR HIGH-CYCLE OPERATION cast iron high-speed flanged bearings on all drives  
add to net price (part no. 50195).....255.00  
PRICES FOR CONTROLS AND ACCESSORIES see pages 38 to 43.  
For additional information see catalogues no. E106A and E113A.



**DOORLEC  
CORPORATION**

MANUFACTURERS OF ELECTRIC OPERATORS FOR  
DOORS, GATES AND TRAFFIC CONTROL, BARRIERS

# MODEL RDO

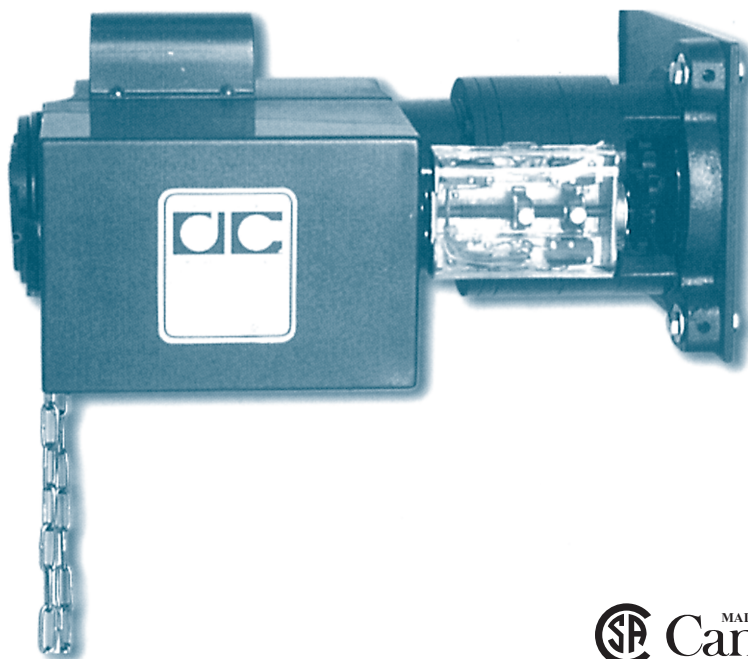

**ROLLING  
CURTAIN  
ELECTRIC  
DOOR OPERATOR  
WITH DC2000  
DEDICATED LOGIC  
CONTROLLER**

**Max. door size: 400 sq.ft. (37m<sup>2</sup>) / unbalanced weight: 4800 lbs (2177 kg)**

MODEL	H.P.	VOLTAGE-PHASE	CONTROL CIRCUIT	NET PRICE
RDO-311	3/4	115-1	24V.A.C.	2260.00
RDO-321	3/4	230-1	24V.A.C.	2260.00
RDO-383	1	208-3	24V.A.C.	2410.00
RDO-343	1	460-3	24V.A.C.	2410.00
RDO-353	1	550-3	24V.A.C.	2410.00

PRICE

Additional control circuit for 115V AC available at no extra charge .

MOUNTING BRACKETS AND FASTENERS (part no. 50630)

add to net price ..... 255.00

DOORS OVER 14' HIGH (for each additional foot)

add to net price ..... 10.50

No. 50 drive chain and sprockets are supplied as standard equipment, for final drive .

PRICE FOR CONTROLS AND ACCESSORIES see pages 38 to 43.

For additional information see catalogues E112 and E113A.

WE ARE NOT RESPONSIBLE FOR CORRECT SPROCKET UNLESS COMPLETE SHAFT INFORMATION IS RECEIVED WITH ORDER.



**DOORLEC  
CORPORATION**

MANUFACTURERS OF ELECTRIC OPERATORS FOR  
DOORS, GATES AND TRAFFIC CONTROL, BARRIERS

# MODEL RDOF

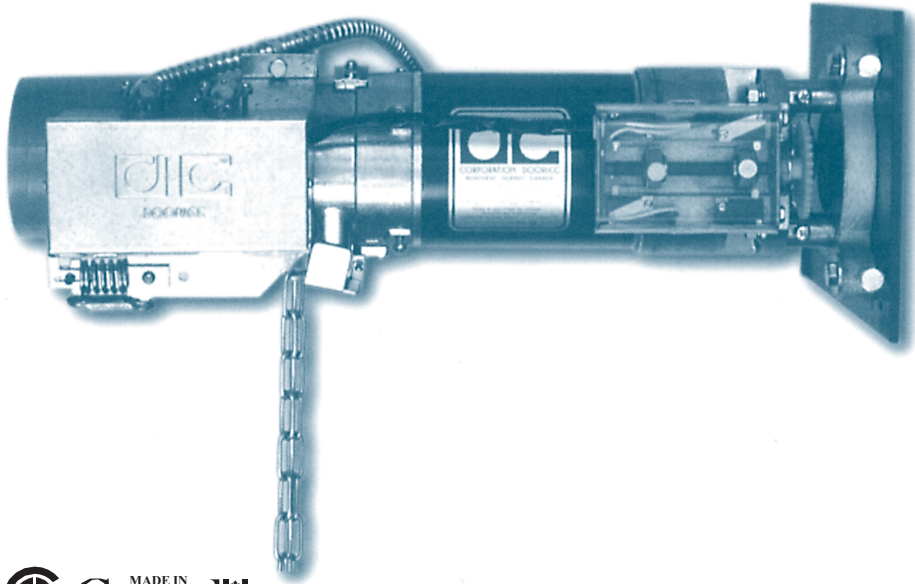

Max. door size: 168 sq.ft. (16m<sup>2</sup>) / unbalanced weight: 2500 lbs (1134 kg)

MODEL	H.P.	VOLTAGE-PHASE	CONTROL CIRCUIT	RETAIL PRICE
RDOF-311	¾	115-1	24V.A.C.	2550.00
RDOF-321	¾	230-1	24V.A.C.	2550.00
RDOF-383	¾	208-3	24V.A.C.	2550.00
RDOF-343	¾	460-3	24V.A.C.	2550.00
RDOF-353	¾	550-3	24V.A.C.	2550.00

PRICE

PRICES INCLUDE FIRE RELEASE SYSTEM.

Additional control circuit for 115V AC available at no extra charge.

MOUNTING BRACKETS AND FASTENERS (part no. 50630) add to net price .....255.00

DOORS OVER 14' WIDE (for each additional foot) add to net price ..... 25.50

No. 50 drive chain and sprockets are supplied as standard equipment, for final drive.

For additional information see catalogue E112 and E113A.

WE ARE NOT RESPONSIBLE FOR CORRECTS PROCKET UNLESS COMPLETE SHAFT INFORMATION IS RECEIVED WITH ORDER.

**ROLLING CURTAIN  
FIRE DOOR  
ELECTRIC OPERATOR  
WITH DC2000  
DEDICATED LOGIC  
CONTROLLER**



**DOORLEC  
CORPORATION**

MANUFACTURERS OF ELECTRIC OPERATORS FOR  
DOORS, GATES AND TRAFFIC CONTROL, BARRIERS

# MODEL SGO

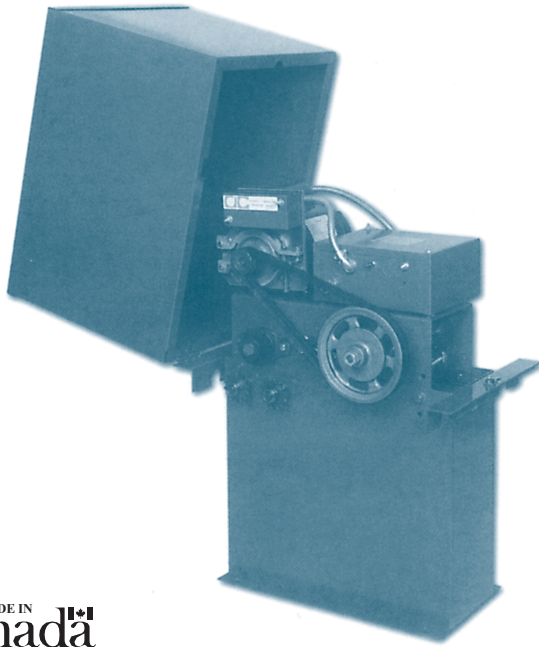

## HORSEPOWER SELECTION GUIDE

MOTOR	GATE TRAVELLING SPEED	MAX. GATE WEIGHT	MAXIMUM OVERHEAD GATE OPENING	MAXIMUM CANTILEVER GATE OPENING	MAXIMUM ROLLER/V-TRACK GATE OPENING
1/3 H.P. 249W	57 ft./min. (17.37 m/min.)	700 lbs. (317.5kg)	20 ft. (6.10m)	12 ft. (3.66m)	16 ft. (7.92m)
1/2 H.P. 373W	60 ft./min. (18.29 m/min.)	900 lbs. (408.25kg)	36 ft. (10.97m)	20 ft. (6.10m)	26 ft. (7.92m)
3/4 H.P. 560W	60 ft./min. (18.29 m/min.)	1200 lbs. (544.31kg)	46 ft. (14.02m)	26 ft. (7.92m)	36 ft. (10.97m)
1 H.P. 746W	60 ft./min. (18.29 m/min.)	1500 lbs. (680.39kg)	58 ft. (17.68m)	232 ft. (9.75m)	48 ft. (17.63m)

MODEL	H.P.	VOLTAGE-PHASE	CONTROL CIRCUIT	RETAIL PRICE
SGO-311	1/3	115-1	24V.A.C.	3790.00
SGO-311	1/2	115-1	24V.A.C.	3940.00
SGO-311	3/4	115-1	24V.A.C.	4010.00
SGO-321	1/3	230-1	24V.A.C.	3790.00
SGO-321	1/2	230-1	24V.A.C.	3940.00
SGO-321	3/4	230-1	24V.A.C.	4010.00
SGO-383	1/3	208-3	24V.A.C.	4010.00
SGO-383	1/2	208-3	24V.A.C.	4160.00
SGO-383	3/4	208-3	24V.A.C.	4300.00
SGO-383	1	208-3	24V.A.C.	4450.00
SGO-343	1/3	460-3	24V.A.C.	4010.00
SGO-343	1/2	460-3	24V.A.C.	4160.00
SGO-343	3/4	460-3	24V.A.C.	4300.00
SGO-343	1	460-3	24V.A.C.	4450.00
SGO-353	1/3	575-3	24V.A.C.	4010.00
SGO-353	1/2	575-3	24V.A.C.	4160.00
SGO-353	3/4	575-3	24V.A.C.	4300.00
SGO-353	1	575-3	24V.A.C.	4450.00

Additional control circuit for 115V AC available at no extra charge  
 FOR POST MOUNT INSTALLATION (part no. 50640) add to net price ..... 450.00

No. 40 drive chain and sprockets are supplied as standard equipment.

PRICE FOR CONTROLS AND ACCESSORIES see pages 38 to 43.

For additional information see catalogues no. E114 and E113A.

**COMMERCIAL  
INDUSTRIAL  
SLIDING GATE  
ELECTRIC  
OPERATOR  
WITH DC2000  
DEDICATED LOGIC  
CONTROLLER**



**DOORLEC  
CORPORATION**

MANUFACTURERS OF ELECTRIC OPERATORS FOR  
DOORS, GATES AND TRAFFIC CONTROL, BARRIERS

# MODEL SGOH

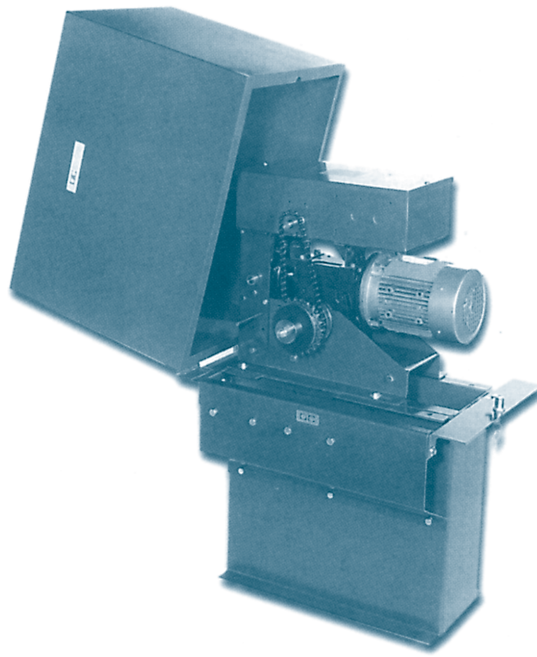

**HEAVY-DUTY  
INDUSTRIAL  
SLIDING GATE  
ELECTRIC  
OPERATOR  
WITH DC2000  
DEDICATED LOGIC  
CONTROLLER**

## HORSEPOWER SELECTION GUIDE

MOTOR	GATE TRAVELLING SPEED	MAX. GATE WEIGHT	MAXIMUM OVERHEAD GATE OPENING	MAXIMUM CANTILEVER GATE OPENING	MAXIMUM ROLLER/V-TRACK GATE OPENING
1/3 H.P. 249W	45 ft./min. (13.7 m/min.)	1250 lbs. (567kg)	46 ft. (14m)	26 ft. (8m)	36 ft. (11m)
1/2 H.P. 373W	45 ft./min. (13.7 m/min.)	1500 lbs. (703kg)	58 ft. (18m)	32 ft. (10m)	48 ft. (15m)
3/4 H.P. 560W	45 ft./min. (13.7 m/min.)	1600 lbs. (726kg)	70 ft. (21m)	38 ft. (12m)	60 ft. (18m)
1 H.P. 746W	45 ft./min. (13.7 m/min.)	2100 lbs. (953kg)	85 ft. (26m)	44 ft. (13m)	72 ft. (22m)

MODEL	H.P.	VOLTAGE-PHASE	CONTROL CIRCUIT	RETAIL PRICE
SGOH -311	3/4	115-1	24V.A.C.	6700.00
SGOH- 311	1	115-1	24V.A.C.	6770.00
SGOH -311	1 1/2	115-1	24V.A.C.	6850.00
SGOH -321	3/4	230-1	24V.A.C.	6700.00
SGOH-321	1	230-1	24V.A.C.	6770.00
SGOH-321	1 1/2	230-1	24V.A.C.	6850.00
SGOH-383	3/4	208-3	24V.A.C.	6770.00
SGOH-383	1	208-3	24V.A.C.	6920.00
SGOH-383	1 1/2	208-3	24V.A.C.	7140.00
SGOH-383	2	208-3	24V.C.A.	7430.00
SGOH-343	3/4	460-3	24V.A.C.	6770.00
SGOH-343	1	460-3	24V.A.C.	6920.00
SGOH-343	1 1/2	460-3	24V.A.C.	7140.00
SGOH-343	2	460-3	24V.A.C.	7430.00
SGOH-353	3/4	575-3	24V.A.C.	6770.00
SGOH-353	1	575-3	24V.A.C.	6920.00
SGOH-353	1 1/2	575-3	24V.A.C.	7140.00
SGOH-353	2	575-3	24V.A.C.	7430.00



**DOORLEC  
CORPORATION**

MANUFACTURERS OF ELECTRIC OPERATORS FOR  
DOORS, GATES AND TRAFFIC CONTROL, BARRIERS

Additional control circuit for 115V AC available at no extra charge

ADJUSTABLE TORQUE LIMITER (part no. 50170) .....885.00

FOR POST MOUNT INSTALLATION (part no. 50640) add to net price .....450.00

No. 50 drive chain and sprockets are supplied as standard equipment.

PRICE FOR CONTROLS AND ACCESSORIES see pages 38 to 43.

For additional information see catalogues no. E114 and E113A.

# MODEL SGP "GATE-MASTER"

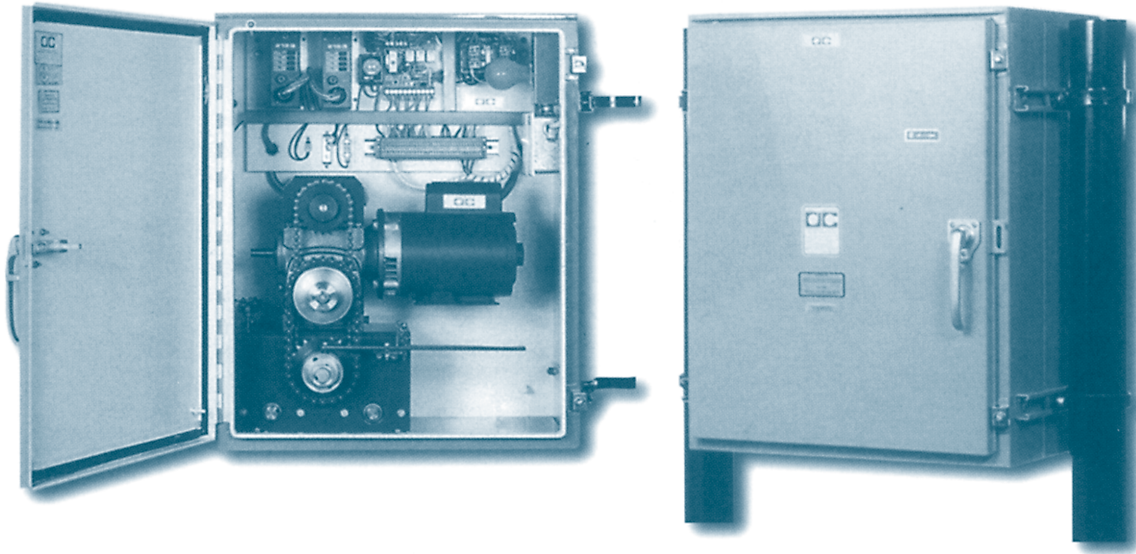

## HORSEPOWER SELECTION GUIDE

MOTOR	GATE TRAVELLING SPEED	MAX. GATE WEIGHT	MAXIMUM OVERHEAD GATE OPENING	MAXIMUM CANTILEVER GATE OPENING	MAXIMUM ROLLER/V-TRACK GATE OPENING
¾ H.P. 249W	45 ft./min. (13.7 m/min.)	1550 lbs. (703kg)	46 ft. (14m)	26 ft. (8m)	36 ft. (11m)
1 H.P. 373W	45 ft./min. (13.7 m/min.)	1850 lbs. (840kg)	58 ft. (18m)	32 ft. (10m)	48 ft. (15m)
1½ H.P. 560W	45 ft./min. (13.7 m/min.)	2100 lbs. (955kg)	70 ft. (21m)	38 ft. (12m)	60 ft. (18m)
2 H.P. 1493W	45 ft./min. (13.7 m/min.)	2500 lbs. (1131kg)	85 ft. (26m)	44 ft. (13m)	72 ft. (22m)

MODEL	H.P.	VOLTAGE-PHASE	CONTROL CIRCUIT	RETAIL PRICE
SGP-311	¾	115-1	24V.A.C.	7140.00
SGP-311	1	115-1	24V.A.C.	7430.00
SGP-311	1½	115-1	24V.A.C.	7720.00
SGP-321	¾	230-1	24V.A.C.	7140.00
SGP-321	1	230-1	24V.A.C.	7430.00
SGP-321	1½	230-1	24V.A.C.	7720.00
SGP-383	¾	208-3	24V.A.C.	7140.00
SGP-383	1	208-3	24V.A.C.	7430.00
SGP-383	1½	208-3	24V.A.C.	7720.00
SGP-383	2	208-3	24V.A.C.	8010.00
SGP-343	¾	460-3	24V.A.C.	7140.00
SGP-343	1	460-3	24V.A.C.	7430.00
SGP-343	1½	460-3	24V.A.C.	7720.00
SGP-343	2	460-3	24V.A.C.	8010.00
SGP-353	¾	575-3	24V.A.C.	7140.00
SGP-353	1	575-3	24V.A.C.	7430.00
SGP-353	1½	575-3	24V.A.C.	7720.00
SGP-353	2	575-3	24V.A.C.	8010.00

### AVAILABLE OPTIONS

MOUNTING CHANNELS WITH SPRING NUTS (#50735).....	240.00
LOCK HANDLE, PADLOCKABLE STAINLESS STEEL (#50730).....	255.00
LIGHT SWITCH ON/OFF WITH 60 WATTS BULB & SOCKET (#50745).....	105.00
PUSH BUTTON OPEN/CLOSE/STOP INSIDE CABINET (#22206).....	75.00
DISCONNECT SWITCH TO MAIN POWER 2 POLE & 3 POLE (#50740).....	240.00
ADJUSTABLE OVERRUN TIMER AS ADDITIONAL PROTECTION TO TORQUE LIMITER (#36301).....	255.00
KEY SWITCH WITH STOP BUTTON ON OPERATOR DOOR FOR SNOW REMOVAL CREW USE (#22157).....	285.00
MONITORING CIRCUIT POSITION OF GATE IN CENTER.....	375.00
STEEL MOUNTING STAND FOR CONCRETE BASE INSTALLATION (if required).....	675.00

## POST MOUNT HEAVY-DUTY-INDUSTRIAL SLIDING GATE ELECTRIC OPERATOR WITH DC2000 DEDICATED LOGIC CONTROLLER

SUPPLIED AS STANDARD EQUIPMENT WITH THIS OPERATOR:

- NO. 50 SPROCKETS AND ROLLER CHAIN
- ADJUSTABLE TORQUE LIMITER
- DISCONNECT SYSTEM FOR MANUAL PUSH & PULL OPERATION
- THERMOSTATICALLY CONTROL 175 WATTS HEATER ADJUSTABLE
- MOUNTING "U" CLAMPS WITH FASTENERS AND REINFORCED STEEL METAL STRAP FOR 3½" PIPE POST
- GUARD FOR SPROCKET & CHAIN
- GATE BRACKETS WITH CHAIN TENSIONNERS

For additional information  
see catalogues no. E117A & E113A  
PRICE FOR CONTROLS & ACCESSORIES  
see pages 38 to 43 .



**DOORLEC  
CORPORATION**

MANUFACTURERS OF ELECTRIC OPERATORS FOR  
DOORS, GATES AND TRAFFIC CONTROL, BARRIERS

# MODEL SWGO



**SP** MADE IN Canada

**RESIDENTIAL  
COMMERCIAL  
SWING GATE  
ELECTRIC  
OPERATOR  
WITH DC2000  
DEDICATED LOGIC  
CONTROLLER**

**Max. gate leaf 15 ft. (4,6 m) / weight 500 lbs. (230 kg)**

MODEL	H.P.	VOLTAGE- PHASE	CONTROL CIRCUIT	RETAIL PRICE
SWGO-311	½	115-1	24V.A.C.	7140.00
SWGO-321	½	230-1	24V.A.C.	7430.00
SWGO-383	½	208-3	24V.A.C.	7720.00
SWGO-343	½	460-3	24V.A.C.	7720.00
SWGO-353	½	575-3	24V.A.C.	7720.00

Additional control circuit for 115V AC available at no extra charge  
 PRICE FOR CONTROLS AND ACCESSORIES see pages 38 to 43.  
 For additional information see catalogues no. E114 and E113A.



**DOORLEC  
CORPORATION**

MANUFACTURERS OF ELECTRIC OPERATORS FOR  
DOORS, GATES AND TRAFFIC CONTROL, BARRIERS



# MODEL SWGOH

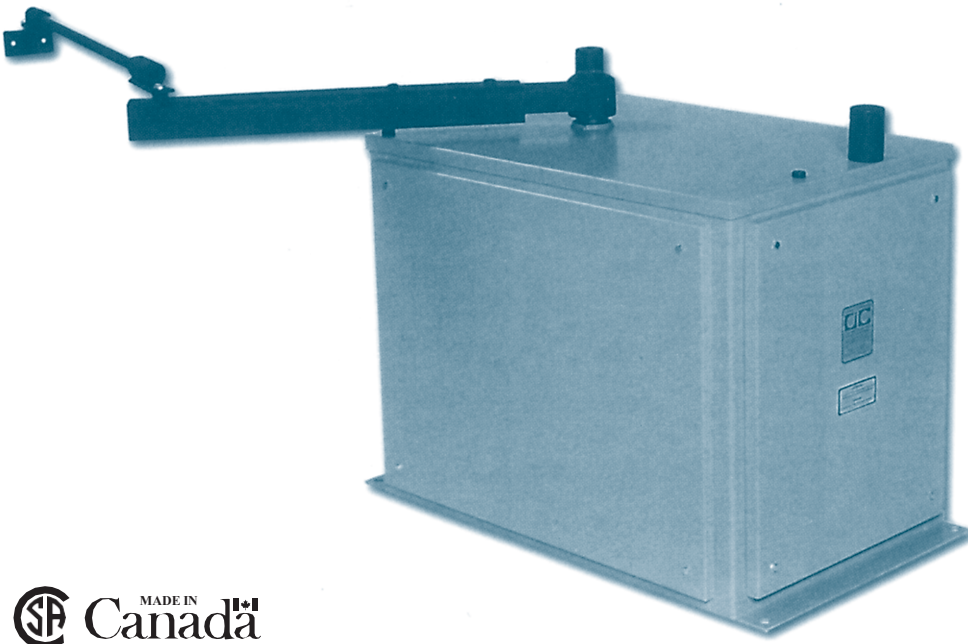

**¾ H.P. maximum gate leaf 19 ft. (5,8 m) / weight 750 lbs. (340 kg.)**  
**1 H.P. max. gate leaf 27 ft. (8,2 m) / weight 1200 lbs. (545 kg.)**

MODEL	H.P.	VOLTAGE- PHASE	CONTROL CIRCUIT	RETAIL PRICE
SWGOH-311	¾	115-1	24V.A.C.	8010.00
SWGOH-311	1	115-1	24V.A.C.	8160.00
SWGOH-321	¾	230-1	24V.A.C.	8010.00
SWGOH-321	1	230-1	24V.A.C.	8160.00
SWGOH-383	¾	208-3	24V.A.C.	8300.00
SWGOH-383	1	208-3	24V.A.C.	8450.00
SWGOH-343	¾	460-3	24V.A.C.	8300.00
SWGOH-343	1	460-3	24V.A.C.	8450.00
SWGOH-353	¾	575-3	24V.A.C.	8300.00
SWGOH-353	1	575-3	24V.A.C.	8450.00

**INDUSTRIAL  
SWING GATE  
ELECTRIC  
OPERATOR  
WITH DC2000  
DEDICATED LOGIC  
CONTROLLER**

Additional control circuit for 115V AC available at no extra charge  
 PRICE FOR CONTROLS AND ACCESSORIES see pages 38 to 43.  
 For additional information see catalogues no. E114 and E113A.



**DOORLEC  
CORPORATION**

MANUFACTURERS OF ELECTRIC OPERATORS FOR  
DOORS, GATES AND TRAFFIC CONTROL, BARRIERS

# MODEL TCBOA

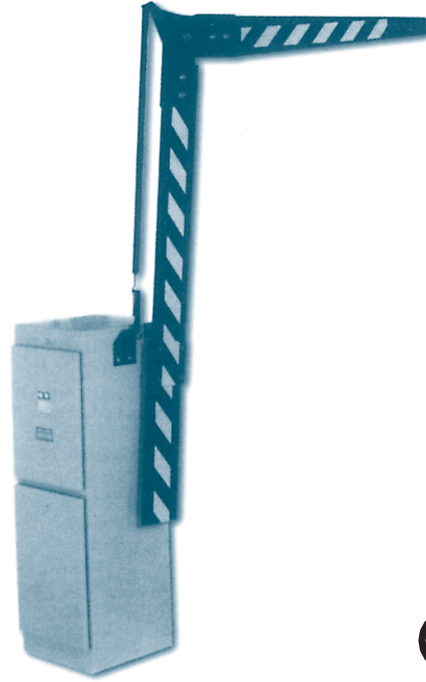

**ARTICULATED ARM  
TRAFFIC CONTROL  
BARRIER ELECTRIC  
OPERATOR  
WITH DC2000  
DEDICATED LOGIC  
CONTROLLER**

**Max. length of articulated arm barrier extended 12 ft. (3.66m)**

MODEL	H.P.	VOLTAGE- PHASE	CONTROL CIRCUIT	RETAIL PRICE
TCBOA-311	1/3	115-1.	24V.A.C.	7430.00
TCBOA-321	1/3	230-1	24V.A.C.	7430.00

Three Phase voltages (208V., 460V., 550V.) are available on request at no extra charge .

Additional control circuit for 115V AC available at no extra charge

PRICE FOR CONTROLS AND ACCESSORIES see pages 38 to 43.

For additional information see catalogues no. E114 and E113A.



**DOORLEC  
CORPORATION**

MANUFACTURERS OF ELECTRIC OPERATORS FOR  
DOORS, GATES AND TRAFFIC CONTROL, BARRIERS

# MODEL TCBOD

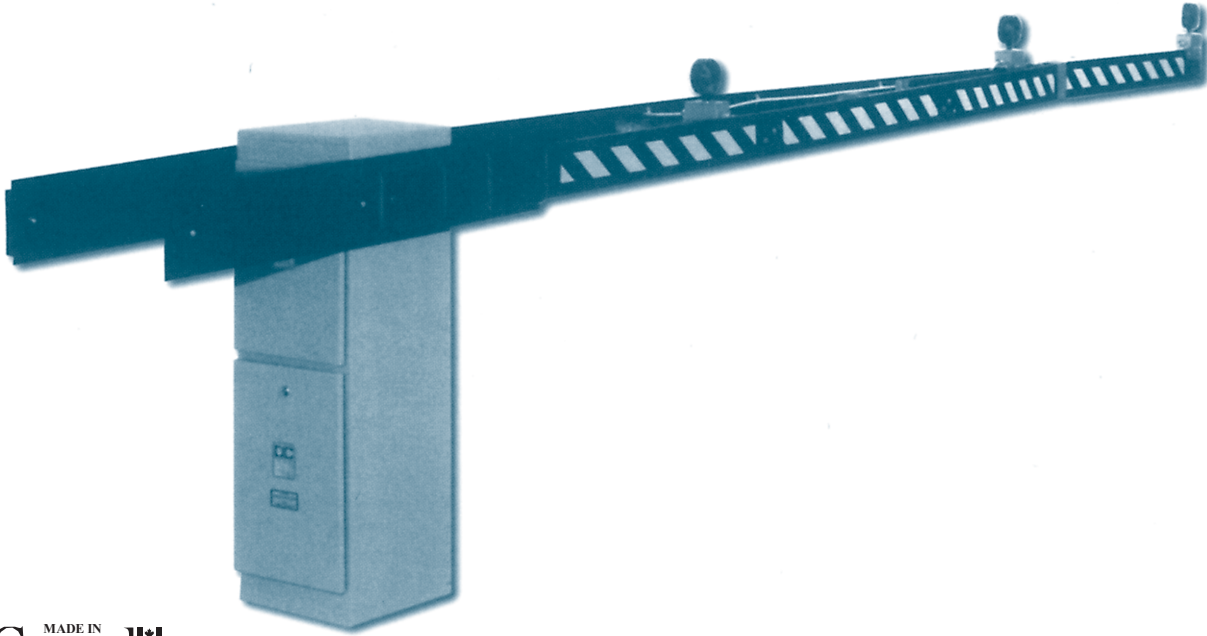

Maximum length of double arm barrier 18 ft. (5.5 m)

MODEL	H.P.	VOLTAGE-PHASE	CONTROL CIRCUIT	RETAIL PRICE
TCBOD-311	½	115-1	24V.A.C.	7570.00
TCBOD-321	½	230-1	24V.A.C.	7570.00

Three Phase Voltages (208V., 460V., 550V.) are available on request at no extra charge.

Additional control circuit for 115V AC available at no extra charge

LIGHT PACKAGE WITH FLASHING RELAY (part no. 50074)

add to net price ..... 855.00

PRICE FOR CONTROLS AND ACCESSORIES see pages 38 to 43.

For additional information see catalogues no. E114 and E113A.

**DOUBLE ARM  
TRAFFIC  
CONTROL  
BARRIER  
ELECTRIC  
OPERATOR  
WITH DC2000  
DEDICATED LOGIC  
CONTROLLER**



**DOORLEC  
CORPORATION**

MANUFACTURERS OF ELECTRIC OPERATORS FOR  
DOORS, GATES AND TRAFFIC CONTROL, BARRIERS

# MODEL TCBO5



**SINGLE ARM  
TRAFFIC  
CONTROL  
BARRIER  
ELECTRIC  
OPERATOR  
WITH DC2000  
DEDICATED LOGIC  
CONTROLLER**

Maximum length of single arm barrier 12 ft. (3.66 m)

MODEL	H.P.	VOLTAGE- PHASE	CONTROL CIRCUIT	RETAIL PRICE
TCBOS-311	1/3	115-1	24V.A.C.	5970.00
TCBOS-321	1/3	230-1	24V.A.C.	5970.00

Three Phase Voltages (208V., 460V., 550V.) are available on request at no extra charge.

Additional control circuit for 115V AC available at no extra charge

PRICE FOR CONTROLS AND ACCESSORIES see pages 38 to 43.

For additional information see catalogues no. E114 and E113A.



**DOORLEC  
CORPORATION**

MANUFACTURERS OF ELECTRIC OPERATORS FOR  
DOORS, GATES AND TRAFFIC CONTROL, BARRIERS

# TERMS AND CONDITIONS

1. Orders for parts ONLY must be a minimum of \$25.00 EXCLUDING replacement of defective material.
2. No returns of parts, controls, accessories or complete operators will be accepted without prior authorization. Return for credit or replacements must be new, unused in their original packaging. A 20% minimum charge will be applied to billing price for verification and restocking. Freight must be prepaid in order for goods to be accepted.
3. Our job/serial number MUST appear on all returns, inquiries, etc. to facilitate quick response.
4. To avoid duplication when mailing purchase orders, please indicate clearly if it is CONFIRMATION ONLY.
5. When ordering accessories, auxiliary equipment, part assemblies, or replacement parts, please use code number to minimize errors.

NOTE 1: For wallmount operators (Jackshaft): Roller chain, drive and driven sprockets are supplied by DOORLEC. If shaft diameter is not specified at time of order, driven sprocket will be provided with 1" bore 1/4" x 1/8" keyway as standard. For models without universal mounting, if mounting position is not specified, RIGHT HAND MOUNT WILL BE PROVIDED, position no. 1 & 3 as shown on drawing no. 3027.

NOTE 2: Lifting capacities of all our operators are based on 10% of unbalanced or dead weight of door/gate; as per charts provided.

NOTE 3: One push button station, open/close/stop is included with each operator at "NO EXTRA CHARGE" with appropriate EEMAC classification.

## ADDITIONAL CONTROL WIRING MODIFICATION AT EXTRA COST

- **FLASHING WARNING LIGHTS:** using winking buttons (Penny Flasher).....\$135.00
- **FLASHING WARNING LIGHTS:** flicker relay 120V AC.....\$525.00
- **WIRING FOR MIDWAY STOP:** Provides capability of selecting midway stop or fully open. To stop door at a predetermined height or fully open as is desired. (part no. 50075).....\$525.00
- **SAFE-PACK WIRING:** 1.5 volt output used with any of our "patented" explosion proof operators, eliminate the use of costly explosion proof cable reel, switches, etc. Permits installation of any of our safety edge systems and cable reels. CSA and ULC approved (part no. 50120).....\$1485.00

**TEFC MOTORS available for ail voltages, including liquid tight conduit and fittings**  
add to unit net price.....\$255.00

**FOR WIRING DIAGRAM & SCHEMATICS** using DC2000 dedicated logic controller see drawing no. 40A, 41A and 42A.

**FOR CONVENTIONAL WIRING CONNECTIONS** see catalogue no. E200A



**DOORLEC  
CORPORATION**

MANUFACTURERS OF ELECTRIC OPERATORS FOR  
DOORS, GATES AND TRAFFIC CONTROL, BARRIERS

# AUXILIARY EQUIPMENT

RETAIL PRICE

Part no. 50130	EMERGENCY TROLLEY-HOIST ASSEMBLY with mechanical release of operator and electrical interlock switch. A disconnect device from floor disengages operator from trolley and engages the chain hoist. Limit switches will not go out of adjustment when hoist is used. Available for models ETH, ETHW, ETBH, ETBHW, ETBX, GT, GTW only. See drawing no. 2007A and 2014 .....	885.00
Part no. 50140	HOIST DISCONNECT without mechanical release from operator has electrical interlock switch, can be incorporated to any door with trolley operator. Lifting door arm must be manually disconnected when hoist is used. See drawing 2007B .....	585.00
Part no. 50145	JACKSHAFT TROLLEY SYSTEM available with any wall mount, jack-shaft electric operator. See drawing 2008A .....	945.00
Part no. 50090	Double V belt drive for all models except ETH-A, ET-3, ETB-3.....	165.00
Part no. 50100	Chain drive in lieu of V-BELT.....	255.00
Part no. 50110	Fire release mechanism available on model EHJ, EHJW, EHJX only.....	435.00
Part no. 50115	Fire release system for tire rated rolling service doors connecting to existing dropout fusible link device.....	1485.00
Part no. 50217	Fire release sliding door arm, purchased separately.....	585.00
Part no. 50215	Sliding door arm purchased separately .....	435.00
Part no. 50600	Splash-proof cover for ail trolley models. See drawing 6058.....	405.00
Part no. 50610	Splash-proof cover for model LJ, LJH, LJHW, GH, GHW, GHX. (See drawing No. 6057 & 6075).....	405.00
Part no. 50615	Splash-proof cover for model EHJ. (See drawing no. 6062) .....	405.00
Part no. 50616	Splash proof cover for model EHJW, EHJX. (See drawing no. 6062) .....	405.00
<b>All above covers are provided with proper fasteners and neoprene gaskets.</b>		
Part no. 50165	Reverse mount used for limited backroom, model ETH-A, ET-3, ETB-3. (See drawing no.3018) (Minimum backroom door height plus 3'-0").....	300.00
Part no. 50160	Reverse mount used for limited backroom, model ETH, ETBH, ETHW, ETBHW, ETBX. (See drawing 3019) (Minimum backroom door height plus 3'-0").....	375.00
Part no. 50225	Cast-iron flanged high-speed bearings in output-shafts of any worm gear driven operator in lieu of oilite bushings. Add to net price.....	180.00
Part no. 50510	Manual crank available for model LJ .....	585.00
Part no. 50520	Manual crank available for models: GH, GHW, GHX in lieu of chain hoist .....	735.00
Part no. 50226	Cast-iron flanged high-speed bearings, on output shafts for model GH-3 and GHW-3 operators in lieu of oilite bushings. Add to net price.....	255.00

# ELECTRICAL PART ASSEMBLIES

Part no. 50180	Brake assembly 120V.....	315.00
Part no. 50181	Brake assembly 208/230V .....	315.00
Part no. 50182	Brake assembly 460V.....	315.00
Part no. 50183	Brake assembly 550V.....	315.00
Brake assembly consist of solenoid, drum, shoes, plate, spring , cover and fasteners		
Part no. 50080	Air switch 2 conductor with housing RED COM. - YELLOW N.O.....	105.00
Part no. 50085	Air switch 3 conductor with housing RED COM. -YELLOW N.O. BLUE N.C. ....	135.00
Part no. 50346	Mechanical safety edge switch with housing & plunger.....	195.00
Part no. 50345	Electric thru-bolt interlock switch.....	225.00
Part no. 50340	Electric overhead door lock 120V .....	1035.00
Part no. 50341	Electric overhead door lock 208/230V .....	1035.00
Part no. 50342	Electric overhead door lock 460V .....	1035.00
Part no. 50343	Electric overhead door lock 550V .....	1035.00
Part no. 50330	Electric swing gate lock 120V .....	2025.00
Part no. 50331	Electric swing gate lock 208/230V.....	2025.00
Part no. 50332	Electric swing gate lock 460V .....	2025.00
Part no. 50333	Electric swing gate lock 550V .....	2025.00
Part no. 50327	Electric sliding gate lock 120V.....	2025.00
Part no. 50328	Electric sliding gate lock 208/230V .....	2025.00
Part no. 50329	Electric sliding gate lock 460V.....	2025.00
Part no. 50334	Electric sliding gate lock 550V.....	2025.00



**DOORLEC  
CORPORATION**

MANUFACTURERS OF ELECTRIC OPERATORS FOR  
DOORS, GATES AND TRAFFIC CONTROL, BARRIERS

# MECHANICAL PART ASSEMBLIES

	<b>RETAIL PRICE</b>
Part no. 50190	41B12 oilite, front idler sprocket..... 90.00
Part no. 50195	41B9 oilite, front idler sprocket..... 75.00
Part no. 50200	410 oilite, front idler sprocket..... 75.00
Part no. 50220	Lifting arm assembly for all trolley models.....120.00
Part no. 50210	Roller chain spreader assembly.....60.00
Part no. 50170	Torque limiter ¾ H.P. up to 2 H.P. motor/reducer.....885.00
Part no. 50175	Torque limiter 3 H.P. motor/reducer.....1185.00
Part no. 50105	Spur gear assembly BSD model (purchased separately.....1125.00
Part no. 50535	Spreader bar for 1" door shaft.....105.00
Part no. 50540	Spreader bar for 1¼" door shaft".....120.00

# CONTROLS & ACCESSORIES

	<b>RETAIL PRICE</b>
<b>PUSH BUTTON STATIONS FLUSH MOUNT</b>	
Part no. 22202	Single button.....105.00
Part no. 22203	Two buttons OPEN/CLOSE.....135.00
Part no. 22210	Three buttons OPEN/CLOSE/STOP.....195.00
<b>PUSH BUTTON STATIONS SURFACE MOUNT</b>	
<b>General purpose EEMAC 1</b>	
Part no. 43545	Single bell button.....8.25
Part no. 22206	Three buttons OPEN/CLOSE/STOPS tandard equipment for all Doorlec operators In general purpose application..... 75.00
Part no. 50405	Single button station.....105.00
Part no. 50410	Two buttons station.....135.00
Part no. 50415	Three buttons station.....165.00
Part no. 50420	Three buttons station with pilot light and key switch OFF/ON..... 405.00
Part no. 50500	Three buttons station with pilot light.....285.00
<b>PUSH BUTTON STATIONS SURFACE MOUNT</b>	
<b>Dust proof-waterproof EEMAC 12 and 4</b>	
Part no. 50425	Single button station.....135.00
Part no. 50430	Two buttons station.....165.00
Part no. 50435	Three buttons station.....195.00
Part no. 50440	Three buttons station with pilot light and key switch OFF/ON..... 435.00
Part no. 50505	Three buttons station with pilot light..... 375.00



**DOORLEC  
CORPORATION**

MANUFACTURERS OF ELECTRIC OPERATORS FOR  
DOORS, GATES AND TRAFFIC CONTROL, BARRIERS

# CONTROLS & ACCESSORIES (cont'd)

RETAIL PRICE

## MULTI-PURPOSE PUSH BUTTON STATIONS AND KEY SWITCHES

Part no. 25050	Push button station OPEN/CLOSE/STOP, explosion proof.....	885.00
Part no. 50442	Alarm mushroom-head push button to open one door or gate.....	165.00
Part no. 50445	Alarm mushroom-head push button to open two doors or gates simultaneously.....	195.00
Part no. 50450	Alarm mushroom-head push button to open three doors or gates simultaneously.....	285.00
Part no. 50455	Alarm mushroom-head push button to open four doors or gates simultaneously.....	315.00
Part no. 50460	Alarm mushroom-head push button to open five doors or gates simultaneously.....	375.00
Part no. 50465	Alarm mushroom-head push button to open six doors or gates simultaneously.....	405.00
Part no. 22211	Three button station "lockable" flush-mount or surface mount stainless steel housing.....	255.00
Part no. 22150	Key switch spring-return with mounting plate.....	37.50
Part no. 22149	Cable release key-switch.....	75.00
Part no. 50030	Key switch spring-return with waterproof housing.....	135.00
Part no. 50325	OFF/ON key switch with waterproof housing.....	165.00
Part no. 22251	Key switches spring-return for open and close "tamperproof".....	405.00
Part no. 22250	Key switch spring-return for open and close with stop button "tamperproof".....	465.00
Part no. 22405	Three button station OPEN/CLOSE/STOP with key switch OFF/ON surface mount.....	375.00
Part no. 22252	Three button station OPEN/CLOSE/STOP with key switch OFF/ON surface mount, "tamperproof".....	465.00
Part no. 22253	Flush mount key switch OPEN/CLOSE "tamperproof".....	345.00
Part no. 22255	Surface mount key switch OPEN/CLOSE EEMAC 4 "tamperproof".....	435.00

## RADIO CONTROLS RESIDENTIAL / COMMERCIAL / INDUSTRIAL

Part no. 17308	Transmitter DC3000T.....	69.00
Part no. 17310	Transmitter two buttons DC3000T-2.....	105.00
Part no. 17300	Transmitter three buttons DC3000T-3.....	135.00
Part no. 17307	Receiver DC3000R.....	105.00
Part no. 17221	Adapter 120V/24V A.C.....	45.00
Part no. 22300	Digital keyless control entry Domino.....	225.00
Part no. 17304	Receiver with antenna DC3000RA.....	285.00
Part no. 17312	Battery 23A-12V.....	20.25
Part no. 17314	Receiver DC3200R industrial EEMAC 1 up to 32 doors or gates.....	525.00
Part no. 17316	Receiver DC3200RW industrial EEMAC 4 up to 32 doors or gates (WATERPROOF).....	735.00
Part no. 17315	Transmitter DC3200T industrial OPEN/CLOSE/STOP up to 32 doors or gates.....	255.00
Part no. 17330	Receiver DC3100R industrial OPEN/CLOSE/STOP.....	285.00
Part no. 17335	Transmitter DC3100T industrial OPEN/CLOSE/STOP with power OFF/ON button.....	165.00
Part no. 17320	Coaxial cable 5 ft. with fitting.....	105.00
Part no. 17350	Cable 5 ft. with antenna.....	15.00
Part no. 17325	Coaxial cable 15 ft. with fitting.....	135.00
Part no. 17355	Cable 15 ft. with antenna.....	30.00
Part no. 17326	Antenna with fitting.....	37.50
Part no. 17103	Transmitter OPEN/CLOSE/STOP pulsar.....	285.00
Part no. 17100	Transmitter OPEN/CLOSE/STOP up to three doors or gates pulsar.....	435.00
Part no. 17102	Transmitter OPEN/CLOSE/STOP up to nine doors or gates pulsar.....	525.00
Part no. 17101	Transmitter OPEN/CLOSE/STOP up to twenty-seven doors or gates pulsar.....	675.00
Part no. 17105	Receiver industrial EEMAC 1 pulsar.....	600.00
Part no. 17106	Receiver industrial EEMAC 4 pulsar.....	825.00

## LOOP DETECTOR, MICRO LOOP PROBE, CARD READER AND PHOTO ELECTRIC SENSORS

Part no. 50026	Loop detector model PD 182 pulse on presence / pulse on leave 24V, with 11 pins base.....	735.00
Part no. 50025	Loop detector model PD 182 pulse on presence / pulse on leave 120V, with 11 pins base.....	735.00
Part no. 38400	Micro loop probe.....	1485.00
Part no. 38506	Loop sealant per tube.....	135.00
Part no. 22315	Key pad EMX-KPX 100 codes commercial.....	675.00
Part no. 22310	Key pad entry 480 codes commercial.....	1425.00
Part no. 50019	Radio control explosion proof, including transmitter, single button OPEN/CLOSE, CSA certified class 1, Division 1, groups CDEFG.....	2685.00



**DOORLEC  
CORPORATION**

MANUFACTURERS OF ELECTRIC OPERATORS FOR  
DOORS, GATES AND TRAFFIC CONTROL, BARRIERS



# CONTROLS & ACCESSORIES (cont'd)

RETAIL PRICE

Part no. 38019	Reflector with hood .....	135.00
Part no. 44452	Pedestal for digital 42" .....	825.00
Part no. 50018	Photo switch polarized reflective with reflectors 3½", explosion proof, Class 1, Division 1, Groupes CDEFG Certified CSA .....	2685.00
Part no. 50020	Photo switch thru-beam type, receiver/transmitter, polarized, explosion proof, Class 1, Division 1, Groupe CDEFG, Certified CSA .....	4350.00
Part no. 50013	Photo switch reflective type 24V IRB-4X RET waterproof for exterior application .....	975.00
Part no. 50010	Photo switch retro-reflective type 24/120/240V .....	525.00
Part no. 50015	Photo switch thru-beam type 24/120/240V .....	585.00
Part no. 50012	Photo switch retro-reflective type 24/120V/240V OMRON .....	675.00
Part no. 50014	Photo switch thru-beam type 24V IRB-4X waterproof for exterior application including car wash systems .....	735.00
Part no. 50016	Photo switch thru-beam type 24/120/240V Sick .....	675.00
Part no. 50017	Photo switch retro-reflective type 24V .....	285.00
Part no. 38017	Réflexor .....	29.25
<b>SAFETY EDGES</b>		
Part no. 50150	Electro-mechanical safety edge, (switch not included) .....	54.00/ft.
	Doors up to 14ft. wide require 1 switch	
	Doors over 14ft. wide require 2 switches	
Part no. 50346	Mechanical edge switch with housing and plunger .....	195.00
Part no. 50155	Electro-mechanical safety edge without switches .....	54.00/ft.
Part no. 35290	Miller edge "T" shape 2" X 2" .....	Contact Doorlec for price
	Specify left or right	
Part no. 35210	Miller edge "U" shape 2" X 2" .....	Contact Doorlec for price
Part no. 50040	Electro-pneumatic reversing safety edge assembly with 20 ft. cable-reel (for doors up to 12 ft. wide) .....	255.00
	Add for each additional foot .....	10.50/ft.
Part no. 50050	Electro-pneumatic safety stop assembly with retractable cord (for doors up to 12ft. wide) .....	330.00
	Add for each additional foot .....	10.50/ft.
Part no. 50045	Electro-pneumatic safety stop assembly with retractable cord (for doors up to 12ft. wide) .....	255.00
	Add for each additional foot .....	10.50/ft.
	Add for cable reel in lieu of retractable cord .....	225.00
Part no. 50053	Electro-pneumatic reversing safety edge assembly with 30 ft. cable reel (for doors up to 12ft. wide) .....	465.00
	Add for each additional foot .....	10.50/ft.
<b>PART No. 50040, 50050, 50045, 50053 DO NOT INCLUDE ALUMINUM RETAINER AND TUBULAR WEATHERSTRIP (ASTRAGAL).</b>		
Part no. 50060	Explosion proof electro-pneumatic reversing weather-strip (for doors up to 12 ft. wide) .....	885.00
	Includes aluminum retainer, tubular weather -strip, air hose, explosion proof air switch, coil hose with fittings. Instant reverse available on both single and three phase motors.	
Part no. 13202	Cable-reel 20 ft . 3 conductors .....	225.00
Part no. 13303	Cable-reel 30 ft. 3 conductors .....	345.00
Part no. 13205	Cable-reel 25 ft . 3 conductors H.D. 16 G.A. wire WOODHEAD or equal .....	555.00
<b>WARNING LIGHTS</b>		
Part no. 50070	Warning lights red/green with mounting bracket, LED .....	975.00
Part no. 50071	Warning lights red with mounting bracket, LED .....	645.00
Part no. 50072	Warning lights green with mounting bracket, LED .....	645.00
Part no. 50073	Warning lights amber with mounting bracket, LED .....	645.00
Part no. 50074	Warning lights package for traffic control barrier TCBOD, Including flashing relay .....	855.00
<b>PULL CORD SWITCHES, WAND etc</b>		
Part no. 50355	Pull cord switch standard .....	105.00
Part no. 50350	Pull cord switch heavy-duty .....	195.00
Part no. 21803	Wand contrai 3 ft. arm extension .....	255.00
Part no. 21800	Utility switch .....	135.00
Part no. 21802	Utility switch with adjustable lever .....	165.00
Part no. 21804	Utility switch with adjustable rod .....	165.00
Part no. 50358	Pull cord switch explosion proof, C.S.A. Certified .....	1185.00



**DOORLEC  
CORPORATION**

MANUFACTURERS OF ELECTRIC OPERATORS FOR  
DOORS, GATES AND TRAFFIC CONTROL, BARRIERS

**TIMERS, FLICKER, AUDIBLE HORN,  
SMOKE ALARM, CYCLE COUNTER**

Part no. 36201	Single timer 0 sec. to 180 sec. 24V. AC.....	255.00
Part no. 36301	Single timer 0 sec. to 180 sec. 120V. AC.....	255.00
Part no. 36203	Dual timer 0 sec. to 360 sec. 24V. AC.....	375.00
Part no. 36202	Dual timer 0 sec. to 360 sec. 120V. AC.....	375.00
Part no. 36101	Timer socket base 8 pins.....	28.50
Part no. 36351	Time delay bi-metal TDA-6.....	29.25
Part no. 36350	Reversing time delay 1.5 sec. 24V. AC.....	135.00
Part no. 36355	Reversing time delay 1.5 sec. 120V. AC.....	135.00
Part no. 36360	Dual time delay 1.5 second 24V.....	165.00
Part no. 36365	Dual time delay 1.5 second 120V.....	165.00
Part no. 36310	Flicker relay "OFF/ON" 120 V. AC.....	435.00
Part no. 22306	Programmable 7 day/24hr. time control.....	1035.00
Part no. 22305	Audible horn 24V. AC.....	645.00
Part no. 22304	Smoke alarm 120V. AC.....	645.00
Part no. 22307	Digital cycle counter 24V. AC.....	525.00
Part no. 22308	Digital cycle counter 120V. AC.....	525.00

**SEPARATE CONTROL CABINETS**

Part no. 42307	Separate control cabinet EEMAC 1.....	1650.00
Part no. 42305	Separate control cabinet EEMAC 12.....	1950.00
Part no. 42306	Separate control cabinet EEMAC 4.....	1950.00
Part no. 50550	Push buttons OPEN/CLOSE/STOPE EMAC 1, 12 or 4.....	285.00

Above prices are based on purchasing a complete Doorlec electric operator combined with any of the above control cabinets. Price includes standard electrical components commonly used by Doorlec, contactor, transformer, overload relay, terminal blocks, cable ducts, markings, wiring diagrams, etc. For complete assembly.

Above cabinets can be purchased separately without the electric door operator. Controls can be substituted to suit your specifications and requirements. Consult Doorlec Corporation for pricing. For EEMAC 7 and 9 Explosion Proof consult Doorlec Corporation for pricing.

All above assemblies are  approved file no. LR-59189.

Part no. 42309	Fusible disconnect 30 amps. open type for EEMAC 1 and 12 cabinets.....	825.00
Part no. 42310	Fuse form II type J:6 amps. or 10 amps.....	28.50
Part no. 42312	Fusible disconnect 30 amps. open type for EEMAC 4 cabinets.....	885.00
Part no. 50125	Fusible disconnect 30 amps, closed type with EEMAC 12 cabinet including 6 amps. or 10 amps. fuses form II type J.....	825.00
Part no. 42313	Fusible disconnect 30 amps closed type EEMAC 1 cabinet (fuses not included).....	405.00

FOR ADDITIONAL INFORMATION SEE CATALOGUE No. E113A

FOR MECHANICAL AND ELECTRICAL REPLACEMENT PARTS SEE PRICE LIST No. E111B  
For parts identification see catalogue No. E201



**DOORLEC  
CORPORATION**

MANUFACTURERS OF ELECTRIC OPERATORS FOR  
DOORS, GATES AND TRAFFIC CONTROL, BARRIERS

# ELECTRIC MOTORS PRICE LIST

RETAIL PRICE

## GENERAL PURPOSE-FRAME 56 - 1725 RPM for V-belt driven models TEFC type.

CODE	SINGLE PHASE		
27020	1/3 H.P.	115/230V MODEL DC 301 .....	980.00
27021	1/2 H.P.	115/230V MODEL DC 201.....	1070.00
27024	3/4 H.P.	115/230V MODEL DC 403.....	1140.00
	THREE PHASE		
27122	1/3 H.P.	208/480/575V MODEL DC 321 .....	980.00
27120	1/2 H.P.	208/480/575V MODEL DC 221.....	1070.00
27119	3/4 H.P.	208/480/575V MODEL DC 423.....	1160.00
27117	1.0 H.P.	208/480/575V MODEL DC 222.....	1260.00

## GENERAL PURPOSE - FRAME 56C - 1725 RPM for worm-gear reducer driven models TEFC type.

CODE	SINGLE PHASE		
27028	3/4 H.P.	115/230V MODEL DC 403C.....	1140.00
27025	1.0 H.P.	115/230V MODEL DC 101C.....	1260.00
27026	1.5 H.P.	115/230V MODEL DC 203C.....	1380.00
	THREE PHASE		
27116	3/4 H.P.	208/480/575V MODEL DC 423 C.....	1140.00
27112	1.0 H.P.	208/480/575V MODEL DC 121 C.....	1260.00
27121	1.5 H.P.	208/480/575V MODEL DC 223 C.....	1380.00
27118	2 H.P.	208/480/575V MODEL DC 224 C.....	1650.00
27209	3 H.P.	208/480/575V MODEL DC 333 C.....	2210.00

## EXPLOSION PROOF MOTORS - FRAME 56 & 56C - 1725 RPM T.E.F.C

For V-belt and worm gear reducer driven models.

CODE	SINGLE PHASE		
27041	1/2 H.P.	115/230V.....	3020.00
27045	3/4 H.P.	115/230V.....	3500.00
27047	1.0 H.P.	115/230V.....	3890.00
27029	1.5 H.P.	115/230V.....	4170.00
27030	3/4 H.P.	208V.....	1460.00
27035	1.0 H.P.	208V.....	1580.00
	THREE PHASE		
27043	1/2 H.P.	208/230/460V.....	3020.00
27044	3/4 H.P.	208 /230/460V.....	3500.00
27048	1.0 H.P.	208/230/460V.....	3890.00
27042	1/2 H.P.	575V.....	3020.00
27046	3/4 H.P.	575V.....	3500.00
27049	1.0 H.P.	575V.....	3890.00
27040	1.5 H.P.	575V.....	4170.00

PRICE FOR 2 H.P. MOTORS CONSULT DOORLEC CORPORATION.

PRICE FOR "STERN" BRAKE MOTORS CONSULT DOORLEC CORPORATION.



**DOORLEC  
CORPORATION**

MANUFACTURERS OF ELECTRIC OPERATORS FOR  
DOORS, GATES AND TRAFFIC CONTROL, BARRIERS

# CONTROLS & ACCESSORIES

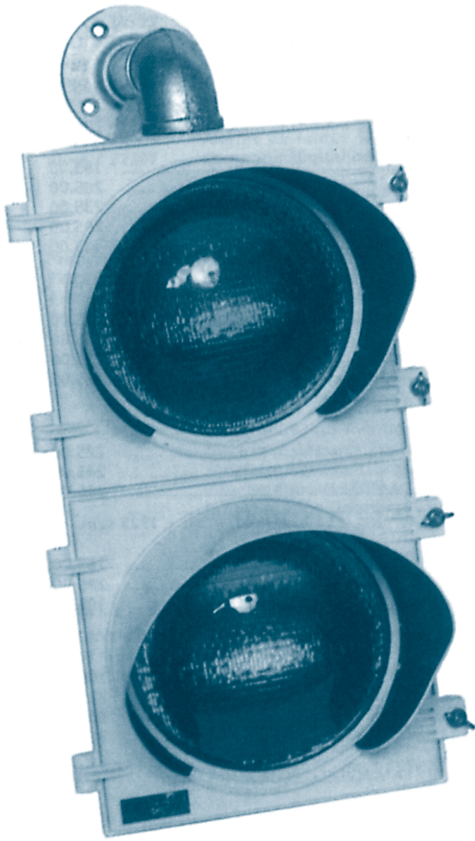

PART NO. 50070

PART NO. 50020

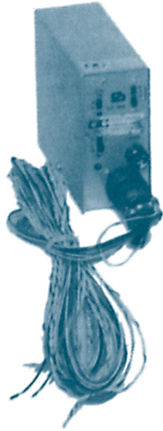

PART NO. 50025



PART NO. 50355

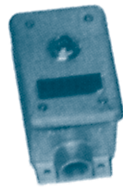

PART NO. 50030

PART NO. 22210



PART NO. 22251

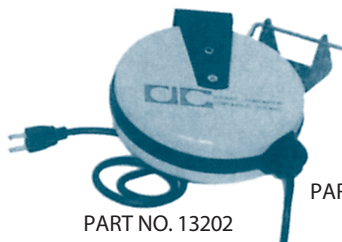

PART NO. 13202

PART NO. 36203



PART NO. 36350



PART NO. 36201

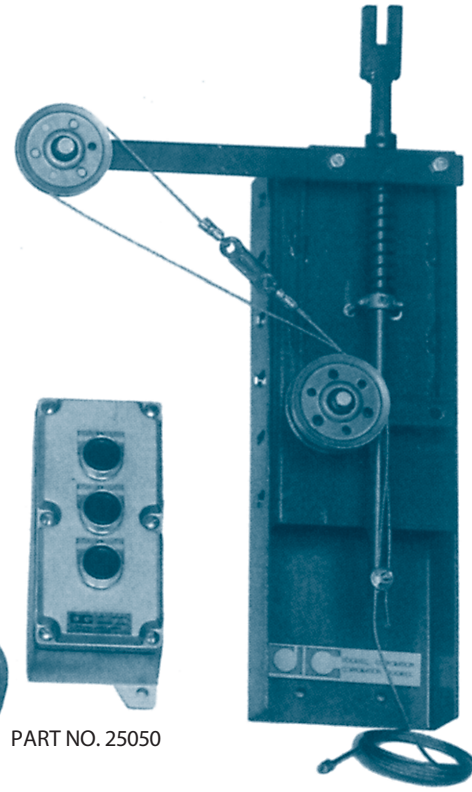

PART NO. 50216

PART NO. 22405



PART NO. 50060

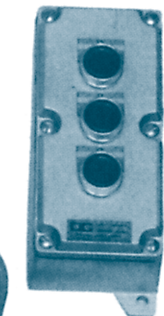

PART NO. 25050

235 Labrosse ave., Pointe-Claire  
Canada H9R 1A9

Tel.: 514-695-0772

1-800-667-0772

Fax: 514-695-0248

1-800-667-0248

info@doorlec.com

[doorlec.com](http://doorlec.com)



DOORLEC  
CORPORATION